

CAMILLA  
STRETCHER  
BRANCARD

# TG-1000 POWER BRAVA

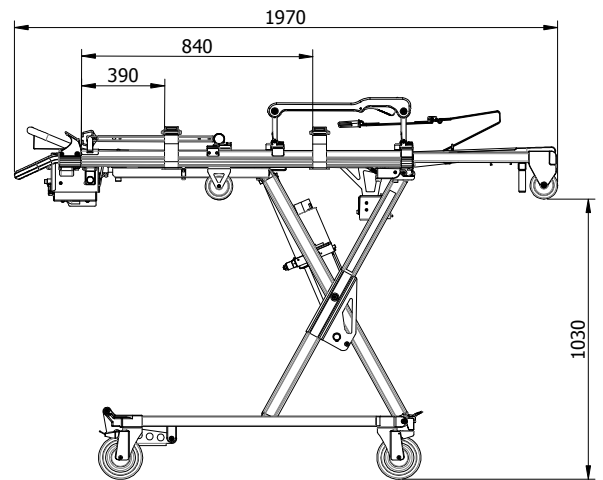

EN - 1865



IEC - 60601  
IEC - 62133

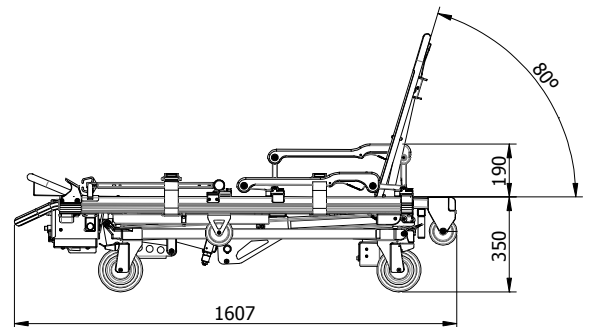
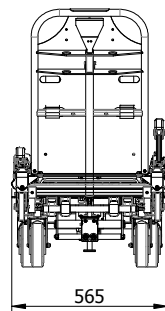

## ESPECIFICACIONES / TECHNICAL DATA / FICHE TECHNIQUE

LARGO	LENGTH	LONGUEUR	1970 mm
ANCHO	WIDTH	LARGEUR	565 mm
ALTURA MIN. / MAX.	HEIGHT MIN. / MAX.	HAUTEUR MIN. / MAX.	350 / 1185 mm
PESO	WEIGHT	POIDS	69 kg
CARGA MAX.	MAX. LOAD	CHARGE UTILE	300 kg

## CARACTERÍSTICAS / FEATURES / CARACTÉRISTIQUES

- Camilla con sistema de elevación hidráulico
- El aluminio es el material predominante de la camilla
- Altura de trabajo regulable
- Cabezal ajustable asistido por amortiguador
- Piernazal de doble articulación asistido por 2 amortiguadores
- 4 ruedas giratorias Ø160 mm (2 bloqueables + 2 con freno)
- Barandillas abatibles longitudinal y lateralmente hacia el exterior
- Porta sueros plegable
- Kit cinturón de tres puntos
- Bandeja en aluminio para masaje cardíaco
- Perfil telescópico en la zona del cabezal para maniobrar en sitios de difícil acceso
- Pulsador de desbloqueo del sistema hidráulico en caso de avería
- Sistema de seguridad para evitar colapso en caso de fallo
- Luces de emergencia

- Stretcher with hydraulic elevation system
- Aluminium is the main material
- Adjustable working height
- Adjustable back rest assisted by shock absorber
- Double folding legs assisted by 2 shock absorbers
- 4 wheels Ø160 mm (2 lockable + 2 with brake)
- Safety rails can be brought down length and width directions
- Folding intravenous drip stand
- Three point belt kit
- Aluminium tray equipped for carrying out heart massage
- Telescopic profile in the back rest to manoeuvre in difficult access situations
- Hydraulic system unlocking button in case of brake down
- Safety system to avoid collapse in case of failure
- Emergency lights

- L'aluminium est la matière prédominante du brancard
- Hauteur de travail réglable
- Relève-buste réglable assisté par un amortisseur
- Repose-jambes à articulation double assisté par 2 amortisseurs
- 4 roues pivotantes Ø160 mm (2 avec blocage + 2 avec frein)
- Barrières rabattables longitudinalement et latéralement vers l'extérieur
- Porte-sérum rabattable
- Kit ceinture trois points
- Plateau en aluminium apte pour la réalisation de massages cardiaques
- Profil télescopique du brancard dans la zone du relève-buste, pour la manipulation dans les zones d'accès difficile
- Bouton de déblocage du système hydraulique en cas de panne
- Système de sécurité pour éviter l'affaissement en cas d'anomalie
- Lumières d'urgence

