

# KARTSANA

Life-moving innovation



SILVER SERIES



# SILVER SERIES



## Strong and light, the perfect balance

Electric stretchers with an excellent design that guarantees comfortable yet safe handling.



### 01

#### 230 kg

Stretcher with a hydraulic elevation system which can lift loads of up to 230 kg unassisted.



### 02

#### Unlocking pedal

Wheels are unlocked using a single pedal to give the operator maximum control.



### 03

#### Control panel

New and improved control panel, now more intuitive, autonomous and functional.



### 04

#### Easy to transfer patients

Laterally and longitudinally collapsible guardrails.

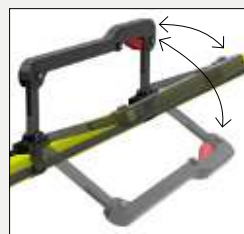

#### Product certification

All KARTSANA products comply with the EN 1865 and 1789 standards.



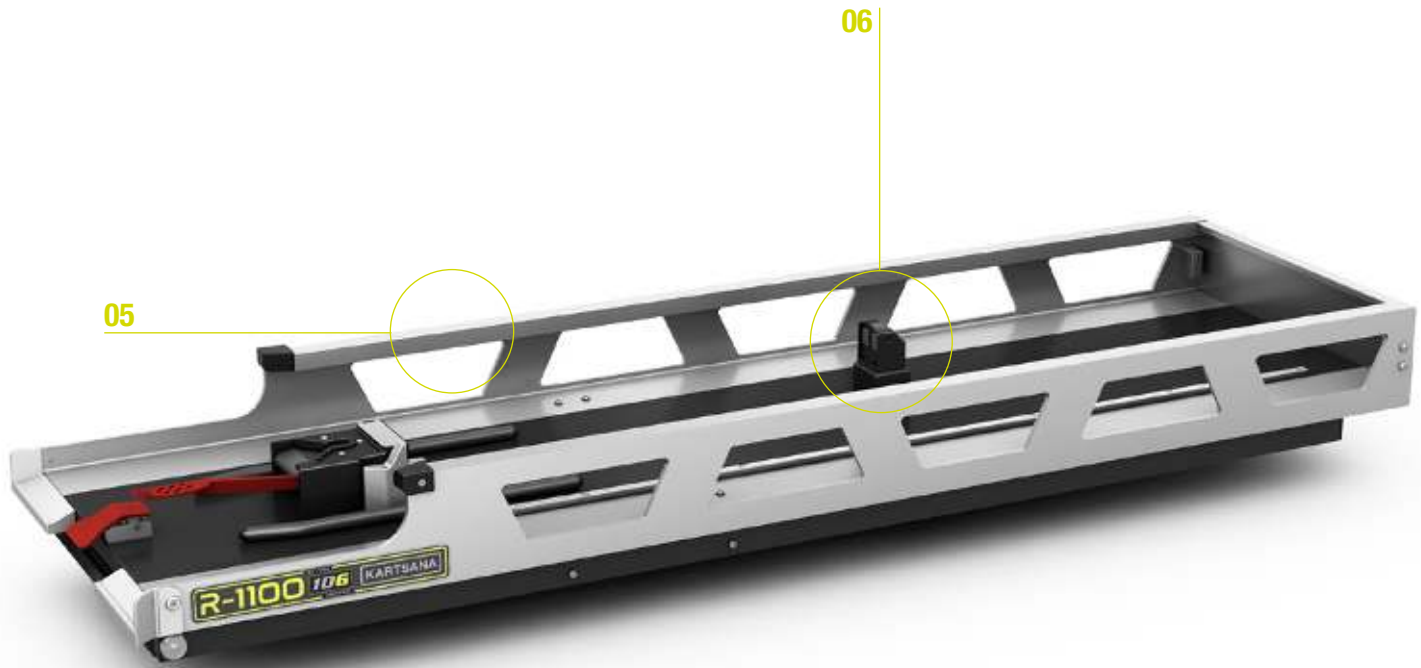
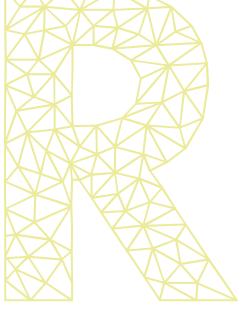

## R-1100, the rail for the SILVER stretcher

**05**

### New design

Now even lighter.



**06**

### Integrated loading system

Batteries charge automatically when inside the ambulance.



# TG-1100 2 / TG-1100 4

- ▷ Adjustable headrest with shock absorber.
- ▷ Single-jointed leg rest with shock absorber.
- ▷ **TG-1100 2**: 2 rotating wheels with brakes + 2 fixed ø160 mm wheels.
- ▷ Guardrails that collapse laterally and longitudinally outwards.
- ▷ Folding IV pole.
- ▷ Three-point safety belt kit.
- ▷ Aluminium tray for performing cardiac massages.
- ▷ Hydraulic system unlocking button in case of fault.
- ▷ **TG-1100 4**: 4 rotating wheels (2 with brakes + 2 lockable wheels).



Aluminium



Electric



230 kg



**Minimal effort**  
for the healthcare  
worker



## DIMENSIONS AND WEIGHT

TG-1100 2 / TG-1100 4	
<b>H</b> Max. height (mm)	1135
<b>HC</b> Max. adjustable height (mm)	786
<b>H2</b> Min. height (mm)	350
<b>L</b> Length (mm)	1955
<b>W</b> Width (mm)	566
Load capacity (kg)	230
Weight (kg)	69

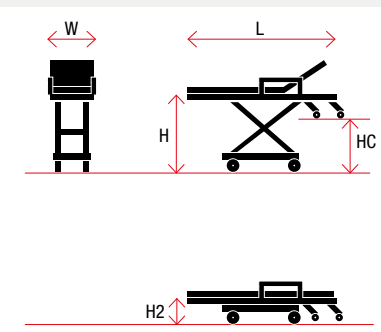

# R-1100

- ▷ Rail for the TG-1100 SILVER stretcher.
- ▷ Extends out of the rear of the ambulance to load the stretcher.
- ▷ Manual operation on two guide tracks.
- ▷ Rail mainly made from aluminium and steel.
- ▷ 3 solid anchoring points to the stretcher.

AI  
Aluminium  
and stainless  
steel



## DIMENSIONS AND WEIGHT

### R-1100

<b>H</b>	Height (mm)	208
<b>L</b>	Length closed (mm)	1996
<b>L2</b>	Length open (mm)	2090
<b>W</b>	Width (mm)	606
<b>A2</b>	Height rail + stretcher (mm)	510
	Weight (kg)	75.5

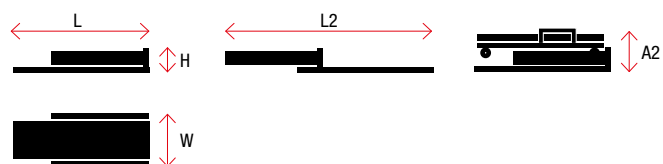



KARTSANA S.L.

Narcís Monturiol, 34  
08192 · Sant Quirze del Vallès  
Barcelona (Spain)  
T.: +34 93 715 86 72  
E.: [info@kartsana.com](mailto:info@kartsana.com)  
[www.kartsana.com](http://www.kartsana.com)

07-2022

© 2022 · Kartsana. All rights reserved.