



DATA SHEET
TG-1000UK

CHEROKEE SERIES

ELECTRIC EQUIPMENT



Aluminium and stainless steel



Electric



- ▷ Adjustable headrest with shock absorber.
- ▷ Double-jointed leg rest with 2 shock absorbers.
- ▷ 4 Ø160 mm rotating wheels (2 lockable wheels + 2 with brakes).
- ▷ Guardrails that collapse longitudinally and fold outwards.
- ▷ Folding IV pole.
- ▷ Three-point safety belt kit.
- ▷ Manual operation system.
- ▷ Push poles.

PRODUCT SPECIFICATIONS

	TG-1000UK
H Max. height (mm)	955
HC Max. adjustable height (mm)	465
H2 Min. height (mm)	940
L Length (mm)	1990
L2 Length closed (mm)	1680
L3 Length open (mm)	1990
W Width (mm)	567
Load capacity (kg)	300
Weight (kg)	78.6

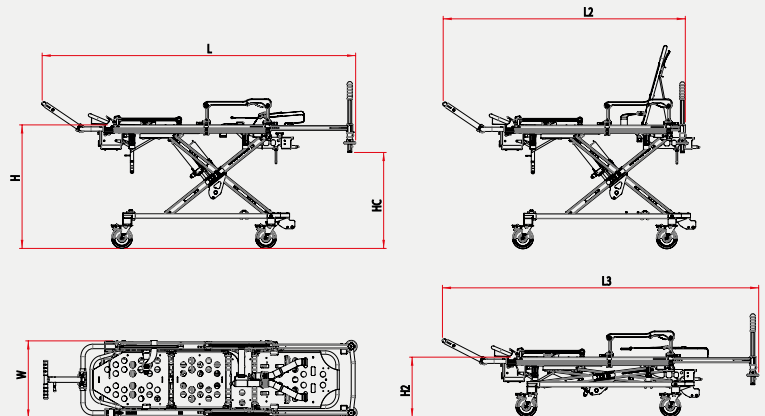

KARTSANA

Life-moving innovation

Narcís Monturiol, 34
08192 - Sant Quirze del Vallès
Barcelona (Spain)

T.: +34 93 715 86 72
info@kartsana.com
www.kartsana.com