

DATA SHEET

TG-1100 2 / TG-1100 4 SILVER

SILVER SERIES

ELECTRIC EQUIPMENT



Aluminium



Electric



230 Kg



CERTIFIED 10G



- ▷ Adjustable headrest with shock absorber.
- ▷ Single-jointed leg rest with shock absorber.
- ▷ **TG-1100 2**: 2 rotating wheels with brakes + 2 fixed \varnothing 160 mm wheels.
- ▷ Guardrails that collapse laterally and longitudinally outwards.
- ▷ Folding IV pole.
- ▷ Three-point safety belt kit.
- ▷ Aluminium tray for performing cardiac massages.
- ▷ Hydraulic system unlocking button in case of fault.
- ▷ **TG-1100 4**: 4 rotating wheels (2 with brakes + 2 lockable wheels).

PRODUCT SPECIFICATIONS

TG-1100 2 / TG-1100 4

H Max. height (mm)	1135
HC Max. adjustable height (mm)	786
H2 Min. height (mm)	350
L Length (mm)	1955
W Width (mm)	566
Load capacity (kg)	230
Weight (kg)	69

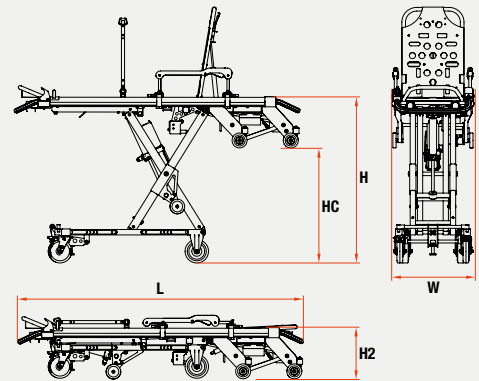

RELATED PRODUCTS



R-1100 SILVER



KARTSANA

Life-moving innovation

Narcís Monturiol, 34
08192 · Sant Quirze del Vallès
Barcelona (Spain)

T.: +34 93 715 86 72
info@kartsana.com
www.kartsana.com