



FICHA TÉCNICA
TG-1000 IN

CAMILLAS PARA INCUBADORAS

EQUIPOS ESPECIALES



Aluminio



Eléctrica



300 kg
sin ayuda



- ▷ Camilla compatible con incubadora para servicios pediátricos.
- ▷ Altura de trabajo regulable.
- ▷ 4 Ruedas giratorias $\varnothing 160$ mm (2 bloqueables + 2 con freno).
- ▷ Pulsador de desbloqueo del sistema hidráulico en caso de avería.
- ▷ Sistema de seguridad para evitar desplome.



* Bandeja superior C-004 no incluida en referencia TG-1000 IN.

DIMENSIONES Y PESO

	TG-1000-IN
H Altura Máx (mm)	1300
H2 Altura Min (mm)	350
L Longitud (mm)	1972
W Ancho (mm)	574
Peso (Kg)	61

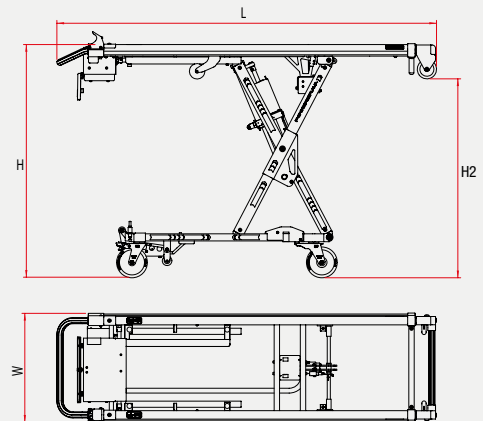

PRODUCTOS RELACIONADOS



R-1001 BRAVO



TG-880 C4 IN



C-004



KARTSANA

Innovación que mueve vidas

Narcís Monturiol, 34
08192 - Sant Quirze del Vallès
Barcelona (España)

T.: +34 93 715 86 72
info@kartsana.com
www.kartsana.com