



DATA SHEET

TG-2022 SUPERBRAVA LITE

SUPERBRAVA SERIES

ELECTRIC EQUIPMENT



Aluminium



Electric



320 Kg unassisted



Water resistant



R10



CERTIFIED 20G



- > Control of the stretcher from the operator's position.
- > Load capacity up to 320 kg without assistance.
- > UTAC 20G certification.
- > Manual engine release by means of an engine clutch system.
- > A single battery with extra capacity reaching 50 cycles tested with 100Kg.
- > Secondary control panel allowing automatic unfolding of the legs.
- > Electronic articulated headrest area.
- > Optional bariatric kit with shoulder support for increased patient comfort.
- > Telescopic headrest profile for manoeuvring in reduced spaces.
- > Emergency lights for safety.
- > Integrated carrying handle for front transfers.
- > Electromagnetic compatibility according to R10 standard.
- > Specific model available for incubators.
- > Waterproof and easy-to-clean design.
- > Includes 2 serum pole. 2 sets of retrofitted telescopic pole dynamic load 10 Kg. approximately.
- > Belts included.
- > Shock or flat leg position.
- > Knee gatch system.
- > The cot legs power -retract within 3 seconds approximately.
- > Retractable head section
- > Expandable patient surface area.
- > Lift-capable safety bar.
- > Retractable head section O2 holder
- > Base storage.
- > Equipment hook & Head end storage flat.
- > Floor-mounted safety hook.
- > Battery IPX6.
- > Adjustable handrails with 6 positions and capacity to accommodate bariatric patients. *Optional.
- > Sealed caster bearings protect against dust and moisture, and reducing the need for maintenance and lubrication.

PRODUCT SPECIFICATIONS

		TG-2022 LITE
H	Max. height (mm)	1240
HC	Max. adjustable height (mm)	1090
H2	Min. height (mm)	370
L	Length (mm)	2070
L2	Length closed (mm)	1733
L3	Length open (mm)	2223
W	Width (mm)	590
	Load capacity (kg)	320
	*Weight (kg)	73,85

* The weight of the mattress and belts are not included.

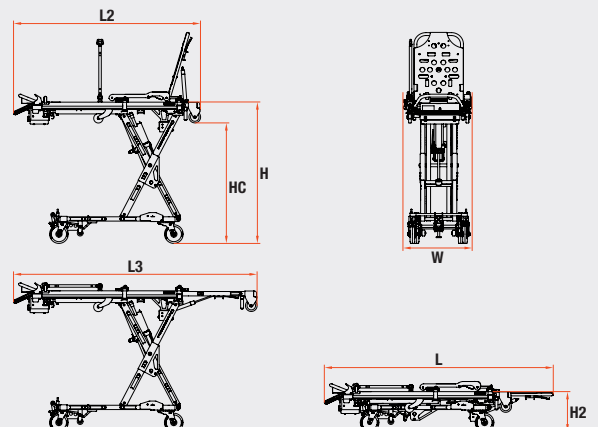

KARTSANA

Life-moving innovation

Narcís Monturiol, 34
08192 · Sant Quirze del Vallès
Barcelona (Espanya)

T.: +34 93 715 86 72
info@kartsana.com
www.kartsana.com

01-2026