

Serie SUPERBRAVA

TG-2022 LITE
TG-2022 IN



KARTSANA

Life-moving innovation

C/ Narcís Monturiol, 34
08192 Sant Quirze del Vallès
Barcelona (Spain)
+34 93 715 86 72
info@kartsana.com
www.kartsana.com

Instruction manual

Electric stretcher SUPERBRAVA LITE / IN

ENGLISH

SUPERBRAVA LITE

Electric stretcher

Model TG-2022



Please read these maintenance instructions carefully before using the product and keep them for future reference.



Electric



R10



CONTENTS

1. INTRODUCTION	4	5. SPARE PARTS	30
1.1 Foreword	4	6. STRETCHER ACCESSORIES	34
1.2 Intended product use	5	7. SYSTEM ERRORS	35
1.3 Liability and warranty	5	7.1 Error codes	35
1.4 Specifications	5	7.2 Troubleshooting	35
1.5 Attention	6	7.3 Motor protection	37
1.6 Summary of safety precautions	6	7.4 Ambulance entry	37
2. INSTRUCTION MANUAL	10	7.5 Battery charging	38
2.1 Technical characteristics of the stretcher	10	8. INCUBATOR VERSION	40
2.2 Vehicle configuration	12	8.1 Product description	40
2.3 Operation and handling of the stretcher	13	8.2 Measures	41
2.3.1 Fitting the batteries	13		
2.3.2 Setting up and control of the stretcher	14		
2.3.3 Adjustable head inclination	15		
2.3.4 Extendable head frame	16		
2.3.5 Adjustable leg	17		
2.3.6 Safety railings	18		
2.3.7 Drip holder	19		
2.3.8 Safety belts	20		
2.3.9 Rear wheel brake lever	21		
2.3.10 Front wheel locking lever	21		
2.3.11 Assembly of the stretcher on the rail R-2022	22		
2.3.12 Transferring the patient to the stretcher	25		
3. USE OF THE EMERGENCY LEVER	26		
4. CARE AND MAINTENANCE	27		
4.1 Contact information	27		
4.2 Environmental conditions	27		
4.3 Cleaning	27		
4.4 Maintenance	28		
4.4.1 Precautionary maintenance	28		
4.4.2 Service maintenance	29		
4.5 Transportation and storage	29		
4.6 Disposal	29		

1. INTRODUCTION

1.1 Foreword

The **SUPERBRAVA LITE (TG-2022)** stretcher has been specifically designed for the rescue and transport of the sick. The product complies with the MDR (EU) Directive 2017/745. It is an electro-hydraulic model that enables the adjustment of the working height according to individual need, with just two push buttons.

There is the option of manual operation for possible malfunctions of the automatic system.

The **SUPERBRAVA LITE (TG-2022)** stretcher model must be attached to the ambulance by means of the **KARTSANA SUPERBRAVO (R-2022)** rail.

This stretcher has been tested in accordance with the UNE-EN 1789 standard. All information on treatment, disinfection and maintenance is based on our experience and current understanding.

We reserve the right to make variations in the technical specifications of the stretcher in order to improve the product.





SUPERBRAVA LITE information sticker



KARTSANA
Life-moving innovation

KARTSANA, S.L.
C/Narcís Monturiol 34
08192 St. Quirze del Vallès
Barcelona (Spain)

Model: **TG-2022**
Commercial name: **SUPERBRAVA LITE**
Voltage: **24V DC**
Max. Power Input: **90W**

JAN	FEB	MAR	APR	MAY	JUN	JUL	AUG	SEP	OCT	NOV	DEC
2022	2023	2024	2025	2026	2027						



- Do not throw away. Send to a recycling centre.
- The packaging should be disposed of as reusable waste.
- Metals should be understood as old material.
- Plastic products should be treated as recycling material.
- Waste management should be as established in each country.
- Please ask the local administration about recycling and rubbish.



Read the instruction manual before use.



Maximum load 320 Kg.



Safety warning and instructions.

1.2. Intended product use

The **SUPERBRAVA LITE (TG-2022)** is a stretcher designed for the transport and support of patients in hospital and pre-hospital environments. The electro-hydraulic lifting system has been developed in order to eliminate the effort required by the caregiver when raising and lowering the stretcher. The product is designed to load patients in a horizontal (supine) or seated position, as well as to facilitate the transport of convenient medical equipment in patient transport or emergency vehicles.

This stretcher has a maximum capacity of 320 Kg and its use requires trained professional operators, including emergency medical services and care home medical staff, and first aid medical teams.

Ambulance stretchers are designed for patient transport and not for prolonged stays, for use as hospital beds, or for the use in devices that modify atmospheric pressure, such as hyperbaric chambers.

1.3. Liability and warranty

The stretcher should be checked when handed over to the relief organisation. All of the functions should be explained in detail. The relief organisation is responsible for training all employees in the correct use of the equipment.

The product has a warranty period of 24 months from the date of delivery to the end user (see *Warranty Conditions and Warranty Certificate* enclosed with the product).

The Warranty will not cover breakdown due to incorrect installation, mishandling or misuse of the product. Repairs must be carried out by a service technician authorised by Kartsana or its authorised representative.

The manufacturer shall not be liable for any damage to the stretcher caused by the use of non-original Kartsana products. Changes or modifications made to the unit that have not been expressly approved by Kartsana may result in errors in the equipment's operation.

1.4 Specifications

Maximum workload (unassisted)	320 Kg
Main regulations	UNE-EN-1865-2 UNE-EN-1865-3 EN-1789+A1 UNE-EN 60601-1 / UNE-EN 61000-6 UL-1642
Articulation/tilting of the backrest	From 0° to 80°
Articulation/tilting of the leg	Double articulation

Diameter of rotating wheels	150 mm
Total length ¹	2090 mm
Total width	590 mm
Minimum and maximum height ²	347 mm - 1240 mm
Loading height ³	Max. 1090 mm
Recommended operators for loading/unloading an occupied stretcher	1 operator or 2 operators in the event that the stretcher is used by a very large person
Compatible restraining systems	R-2022 Superbravo Rail

¹The overall length can be shortened with the headrest extension retracted to a minimum and the backrest folded to 80°.)

²Height from the floor to the top surface of the structural profiles of the patient area of the stretcher at its minimum and maximum height position.

³If the patient is heavy, it is recommended to carry out the movements with the stretcher at a low height.

Kartsana reserves the right to change the specifications without prior notice

1.5 Attention

Throughout this manual, there are 3 types of symbols. As a **warning symbol**, we have ISO 7010-W001. The **prohibition** is indicated by ISO 7010-P001 and the **obligation** by ISO 7010-M001.



Using these symbols, we provide information on important safety measures for the correct use of the stretcher and to avoid possible accidents.

Warnings alert the reader to situations that, if not avoided, may lead to death or serious injury. Furthermore, prohibitions indicate actions that must not be carried out under any circumstance, and obligations indicate measures and/or actions that must be taken to ensure the proper use of the product and to maintain safe functionality.

1.6 Summary of safety precautions

Read and follow the warnings and cautions on these pages carefully. Maintenance and repairs may only be carried out by qualified personnel.



NOTICES

- Improper use of the stretcher may cause injury to the patient or the handler. Use the stretcher only as described in this manual.
- Do not modify the stretcher or any of its components.

Modification of the device may result in an unpredictable operation that could cause injury to the patient or operator. Modification of the device voids the warranty.

- The emergency vehicle where this stretcher is used, must have a compatible restraining system installed.
- The emergency vehicle fastening system compatible with our stretcher must be correctly installed for correct attachment of the stretcher. Otherwise injury to patient, operator or vehicle could occur.

- Do not attempt to operate the stretcher when it is fully and correctly secured to its fastening system in the vehicle.
- Request the correct installation of the fixing rail to the vehicle floor. The position of this rail will determine the correct functioning of the stretcher. After installation, check that the wheels and forks of the stretcher are raised and do not come into contact with the bumper of the vehicle.
- To avoid risk of electric shock, do not attempt to open the battery for any reason. If the battery case is cracked or damaged in any way, do not insert the battery into the charger. Return the battery to be replaced with a good battery.
- Do not remove the battery when the stretcher is charging inside the ambulance.
- Avoid direct contact with the battery or battery casing when wet, as this may cause injury to the patient or operator.
- Check batteries and chargers for damage before each use.
- Practice changing the height and load positions of the stretcher until you have fully mastered the operation of the product. Improper use can lead to injury.
- Do not allow untrained assistants to help you use the stretcher. Inadequately trained technicians and assistants can cause injury to the patient and to themselves.
- Do not climb on the base of the stretcher as this may damage the product, unbalance the patient and cause injury.
- Transporting the stretcher on its side could cause it to tip over, which could damage the product and cause injury to the patient. Transporting the stretcher in a lowered position reduces the chances of the stretcher tipping over.
- Incorrect fastening of the stretcher may result in injury. Avoid putting hands, fingers or feet on any moving parts of the stretcher. To avoid injury, when raising and lowering the stretcher, be very careful when placing hands and feet close to the moving structure (the structural scissors).
- Always use all the restraining belts to secure the patient on the stretcher. If not properly restrained, the patient could fall off the stretcher and injure him or herself.
- Never leave a patient unattended on the stretcher, as they may become injured. When transporting a patient, hold the stretcher firmly in place.
- Do not lock the lower wheels if you want to move the patient. The stretcher could tip over if an attempt is made to move the stretcher with the brakes locking the wheels engaged, with the risk of injury to the patient or operator, and damage to the stretcher.
- Side rails are not designed to be used as a means of restraint.
- In order to obtain the best monitoring results, it is recommended that the patient be monitored when the stretcher is not moving.
- Architectural barriers such as curbs, steps or uneven terrain can cause the stretcher to tip over, potentially injuring the patient or operator.
- The SUPERBRAVA LITE (TG-2022) stretcher is designed to be compatible with the Superbravo rail (R-2022), and it is the responsibility of the operator that these products work together.
- If the stretcher is occupied by a person of large size, we recommend two operators to handle the stretcher and secure the patient.
- Operators must be able to lift the full weight of the patient, stretcher and additional stretcher elements.
- The higher the operator has to lift the stretcher, the more difficult it will be to support the weight. If the operator is very short or if the patient is too heavy to be lifted safely, assistance may be required to load the stretcher. A short operator will have to raise his or her arms higher in order to unfold the lower part of the stretcher.
- When cleaning, use appropriate personal protective equipment (protective goggles or respirators) to avoid the risk of inhaling infectious organisms.
- Some cleaning products are corrosive and can damage the product if used incorrectly. If the products described above are used to clean Kartsana equipment, steps should be taken to ensure that the stretchers are cleaned with clean water and thoroughly dried after cleaning. Failure to properly rinse and dry the units may leave a corrosive residue on the surface of the units, which may cause premature corrosion of critical components.
- Failure to properly clean or improperly dispose of a contaminated mattress or other components increases the risk of exposure to blood-borne pathogens and could result in injury to the patient or operator.
- To avoid risk of injury, wear gloves when checking hydraulic connections for leaks.
- Take special precautions for electromagnetic compatibility (EMC) when using medical electrical equipment such as the Superbrava lite (TG-2022) stretcher. The use of portable and mobile radio frequency (RF) communications equipment may affect the operation of the Superbrava lite (TG-2022).



PRECAUTIONS

- Changes or modifications to the unit not expressly approved by Kartsana may void the user's authority to operate the system.
 - The stretcher can be adjusted to any loading height position. Before the stretcher is put into service, establish the required loading height of the stretcher.
 - Adjust the loading height of the stretcher to the appropriate standing height before use.
 - Installation of the stretcher-compatible fixing rail must be carried out by a certified mechanic familiar with the ambulance structure. Consult the vehicle manufacturer before installing the rail and ensure that the installation does not damage or interfere with the vehicle's brake, oxygen or fuel hoses, fuel tank or electrical wiring.
 - Use the battery and charger only as described in the user/maintenance manual.
 - The stretcher cannot be used with an AC adapter.
 - If charging the battery in the ambulance, place the charger in a locked cabinet out of reach of the patient during transport.
 - Check that the battery is fully charged before putting it into service. A discharged or flat battery may result in poor stretcher performance.
 - If the battery charge becomes excessively discharged, the battery must be charged with the external battery charger. Do not attempt to charge the excessively discharged battery with your Superbravo Rail (R-2022) charging point.
 - Before putting the stretcher into operation, remove all obstacles that may interfere and cause injury to the operator or patient.
 - When unloading the stretcher from the ambulance compartment, make sure that the rotating wheels are placed securely on the ground, otherwise the product may be damaged.
 - Remove the battery if the stretcher is not to be used for an extended period of time (more than 24 hours).
 - The wheel brakes are uniquely designed to help prevent the stretcher from rolling away when unattended and to make it easier to transport patients. The wheel brakes may not offer sufficient resistance on all surfaces or with weight.
 - Ensure that the safety belts do not become entangled in the base frame when raising and lowering the stretcher.
 - Do not store any objects under the stretcher mattress. Storing objects under the mattress may interfere with the functioning of the stretcher.
 - Do not use steam or ultrasonic cleaners to clean the unit.
 - During cleaning, the maximum water temperature must not exceed 80°C.
- Do not use compressed air to dry the stretcher! Allow it to air dry.
 - Dry all rotating wheels and keypads with a towel.
 - Failure to comply with these instructions may result in some or all of the warranties becoming void.
 - Before cleaning the stretcher, remove the battery.
 - A preventive maintenance programme should be established for all Kartsana equipment. Depending on the product's frequency of use, more frequent maintenance may be required. Close attention must be paid to the safety features, which include, among others: the hydraulic mechanism and electrical controls.
 - For further information on maintenance, please refer to the information on preventive maintenance.
 - Improper maintenance may cause injury or damage to the product. The stretcher should be maintained as described in this manual. Follow the maintenance procedures and use only Kartsana approved parts. The use of unapproved parts or procedures may result in an unpredictable operation and may cause injury and void the warranty.
 - Failure to use authorised spare parts, lubricants, etc. may damage the stretcher and void the product warranty.
 - Hydraulic lines, hoses and fittings can fail or become detached due to physical damage, kinks, wear and environmental exposure. Regularly check hoses and lines to prevent damage to the stretcher. Tighten any loose connections.



NOTES

- Loose elements or dirt accumulation on the floor of the ambulance compartment can interfere with the operation of the rail and the stretcher retaining system. Keep the floor of the patient compartment clean.
- This manual should be considered as part of the stretcher and as such should be kept with the product even if the stretcher is sold.
- Kartsana works constantly to improve the design and quality of its products. Therefore, although this manual contains the most current information available at the time of printing, there may be minor discrepancies between the stretcher and this manual. If you have any questions, please contact Kartsana's customer service or technical service area.
- Kartsana recommends that, prior to installation, a certified mechanic should plan the placement of the mounting rail on the inside of the emergency vehicle.
- Automatic charging is only possible with batteries supplied by Kartsana.
- With the Superbrava lite (TG-2022) use only Kartsana approved batteries.
- If the battery is not on the charger, it slowly loses charge.

2. INSTRUCTION MANUAL

2.1. Technical characteristics of the SUPERBRAVA LITE (TG-2022) stretcher



Do not damage the areas where the stretcher mechanisms are located in order to avoid malfunctioning of the stretcher mechanisms.

Stretcher weight: 78 Kg

Dimensions and measurements in mm



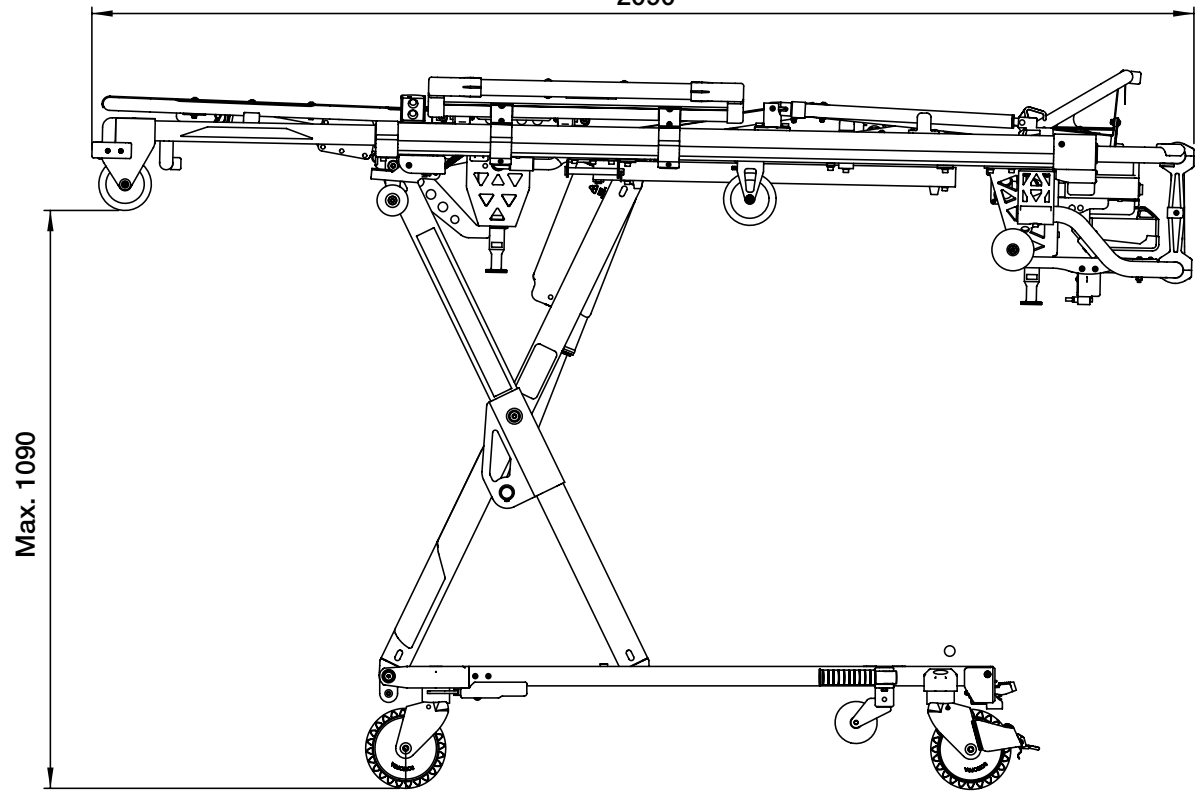
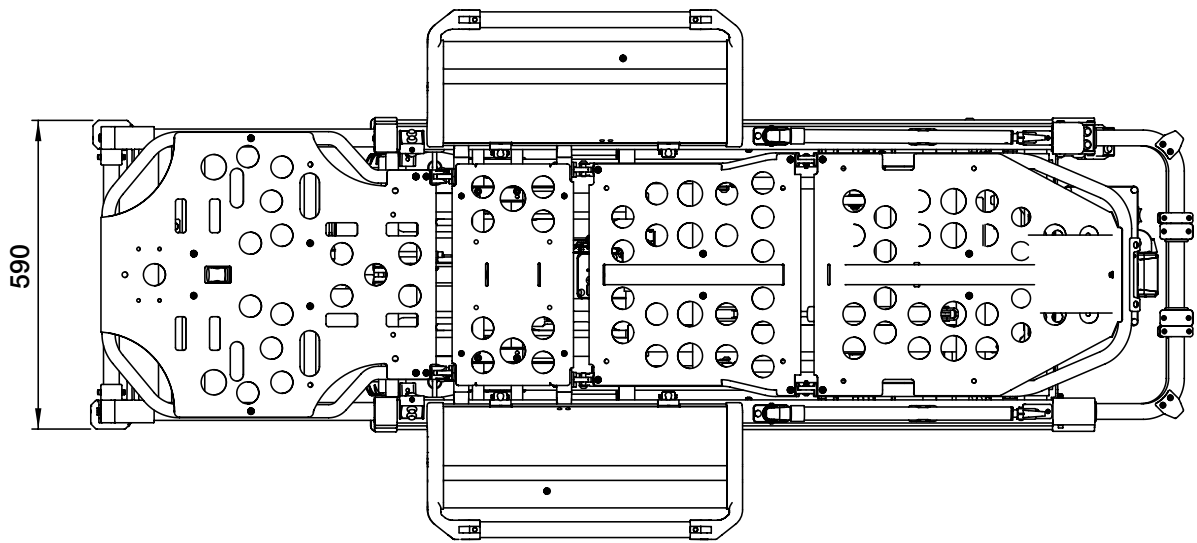

Stretcher with folded legs:

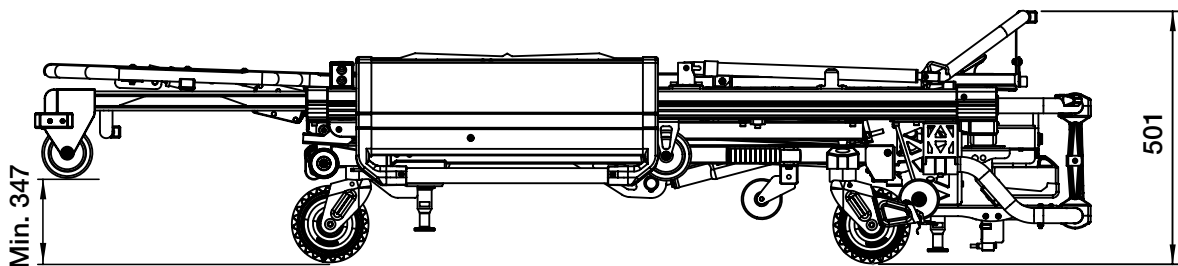

2.2. Vehicle configuration

These installation instructions are indicated for the attachment of the Kartsana SUPERBRAVA LITE (TG-2022) - SUPERBRAVO (R-2022) assembly.

The correct use and operation of the Superbrava lite (TG-2022) stretcher depends on the correct installation of the fastening system (Superbravo R-2022 rail) in the ambulance.



The height of the ambulance floor in relation to the ground must not exceed 80 cm.

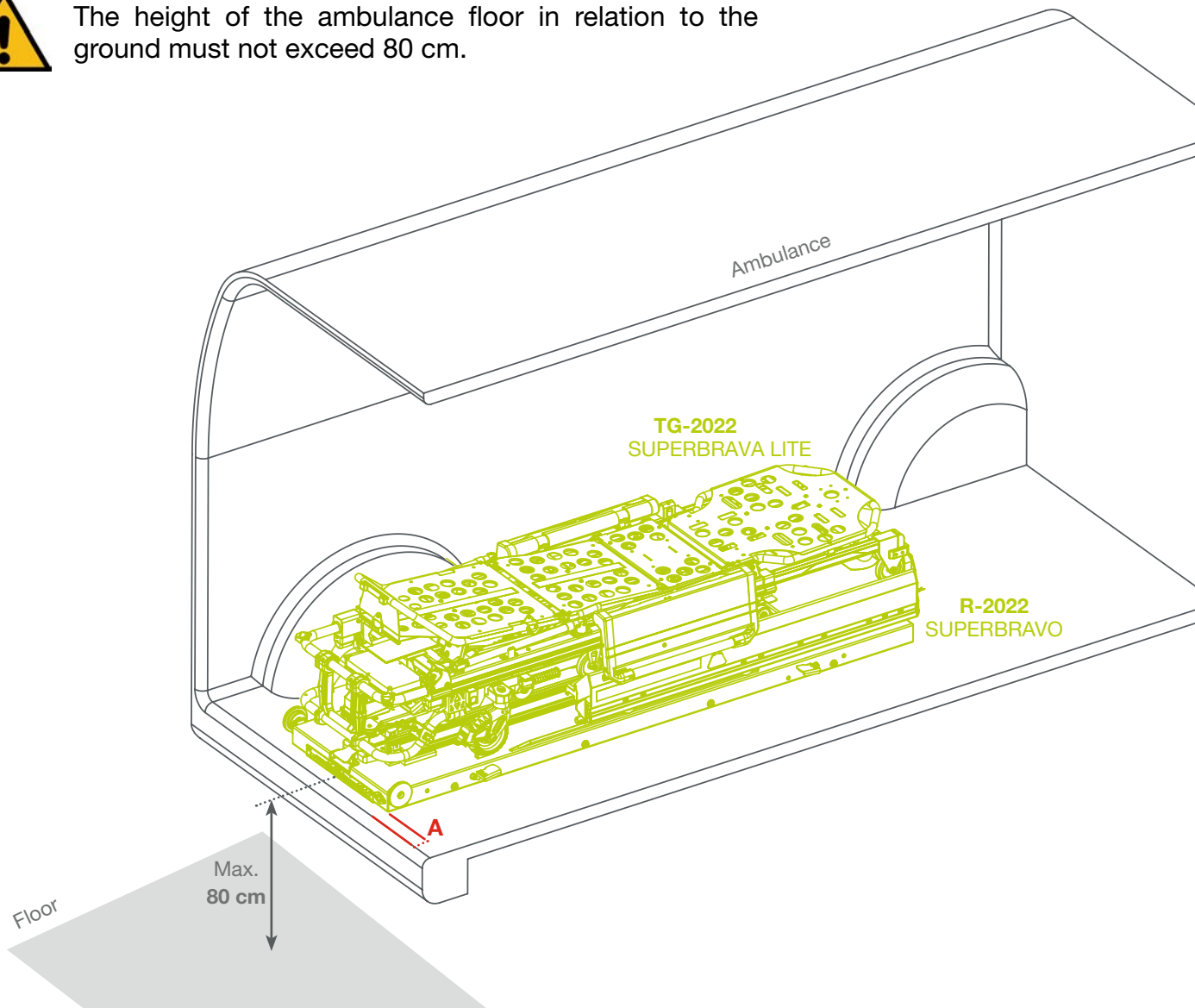

The fixed part of the rail should be fixed at a **distance of approx. 50 mm. (A)** from the rear door of the ambulance (from the rectangular base of the stainless steel).

Depending on the ambulance model and the type of rear **bumper**, the fixing dimensions may vary and/or be adapted.

The maximum distance between the edge of the bumper and the end of the floor attachment **must not exceed 37 cm**. This ensures that the stretcher can be deployed without coming into contact with the bumper.

2.3 Operation and handling of the stretcher

2.3.1 Fitting the batteries

The first step in working with the Superbrava lite is to fit the 28 V battery that powers the system. It is positioned at the rear (at the patient's feet) in the operator's monitoring area.

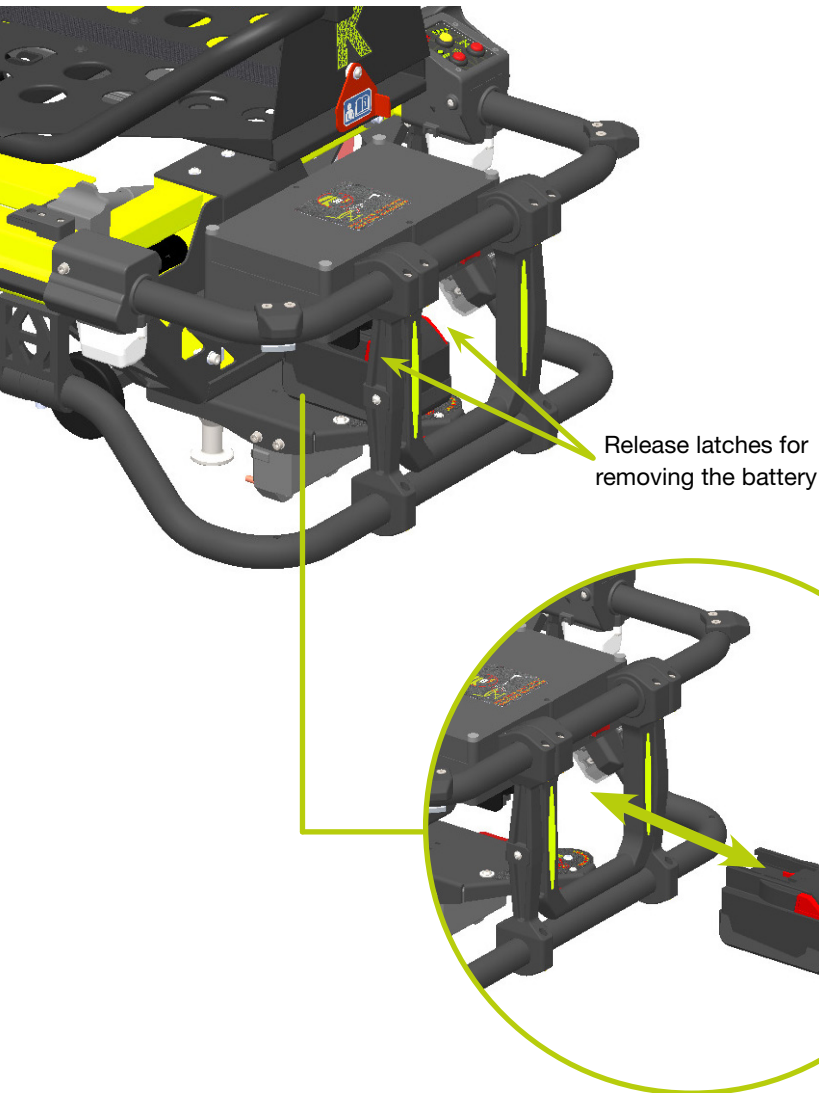

To remove the battery, press the red buttons simultaneously, and pull to unclip the battery from its connector.

The battery's autonomy in no-load operation (no load) should be about 130 cycles.

Information note: The battery is delivered with a minimum charge. Before operating the stretcher, the batteries must be charged with the supplied charger until the LED on the charger turns green. After that, we will be able to work normally.



If the battery becomes excessively discharged, the battery must be charged with the external battery charger. Do not attempt to charge the excessively discharged battery with its Superbravo Rail (R-2022) charging point.



To charge the batteries outside the ambulance, the specific charger is included with the stretcher.

2.3.2 Setting up and control of the stretcher

To avoid possible injury to the patient and attendants in the event of an accident, do not place objects in the path of the moving parts of the stretcher. It is also recommended to avoid protruding elements inside the ambulance.

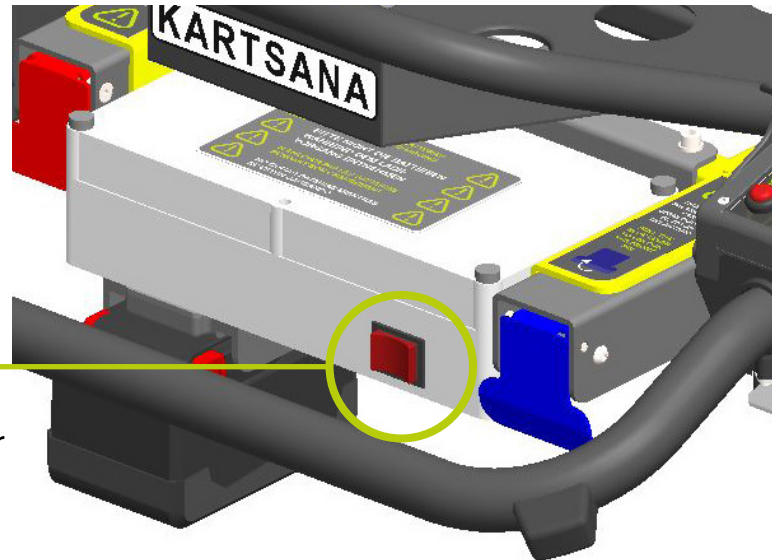

The system starts up once the battery is connected to the stretcher and the power switch is turned on. The number of LEDs lit on the control unit will indicate the charging status of the control unit.

If an error occurs during the self-control process, this will be indicated by the error LEDs (see error table in chapter 7).

Functions of the buttons on the control panel:

Contoured control buttons on the keypad function as follows:

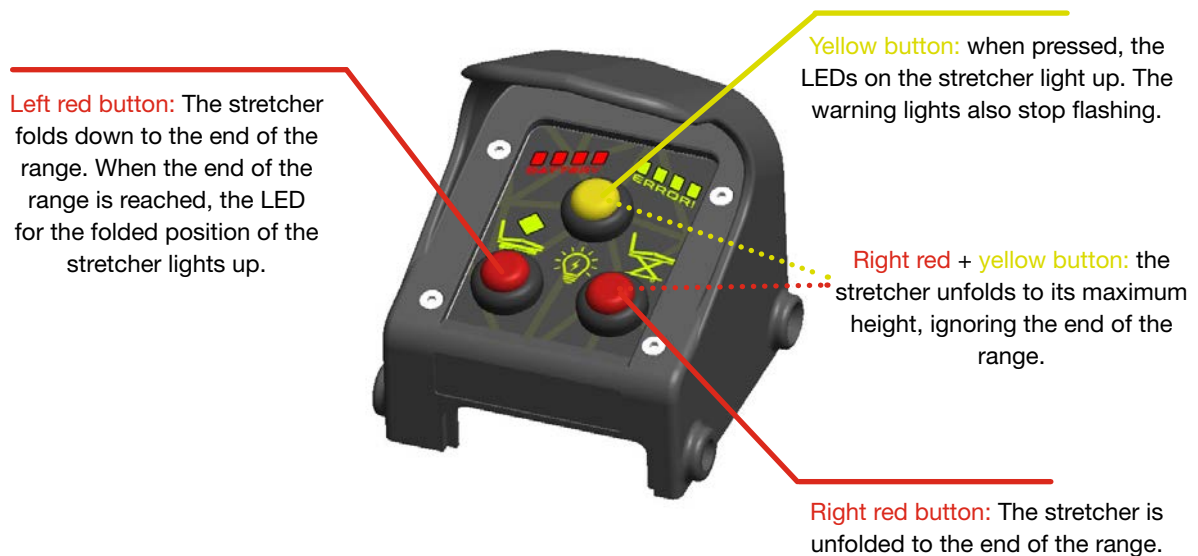

The stretcher goes into low-power Stand-By mode if no key is pressed for 60 minutes. Simply press any button to turn the stretcher back on.

Functions of the auxiliary control panel:

The buttons on the auxiliary control panel function as follows:

Left red button: The stretcher folds down to the end of the range. When the end of the range is reached, the LED for the folded position of the stretcher lights up. It will fold completely with a single push to the end of the range if the stretcher is positioned on the rail. This cycle can be interrupted by touching any button.



Right red button: The stretcher is unfolded to the end of the range. It will fully deploy with a single push to the end of the range if the stretcher is positioned on the rail. This cycle can be interrupted by touching any button.

2.3.3. Adjustable head inclination with pneumatic support

The movement of the head is controlled by the auxiliary monitoring controls on the right and left side of the stretcher. The system allows the head to be positioned at the desired inclination.

Upper red button This is the key on the head (UP). Raising the head to the end of the range.

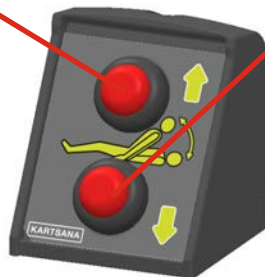

Lower red button: This is the DOWN button The head is lowered to the end of the range.

In the event of malfunction, the system can be manually disengaged and the stretcher head can be left in the rest position (0°).



2.3.4. Extendable head frame

Before carrying out this operation, it is necessary to have the head raised to its maximum position.

To remove or fold the telescopic head frame, it is necessary to operate one of the two red handles located on each side of the stretcher. Stretching or pressing the head frame at the same time.

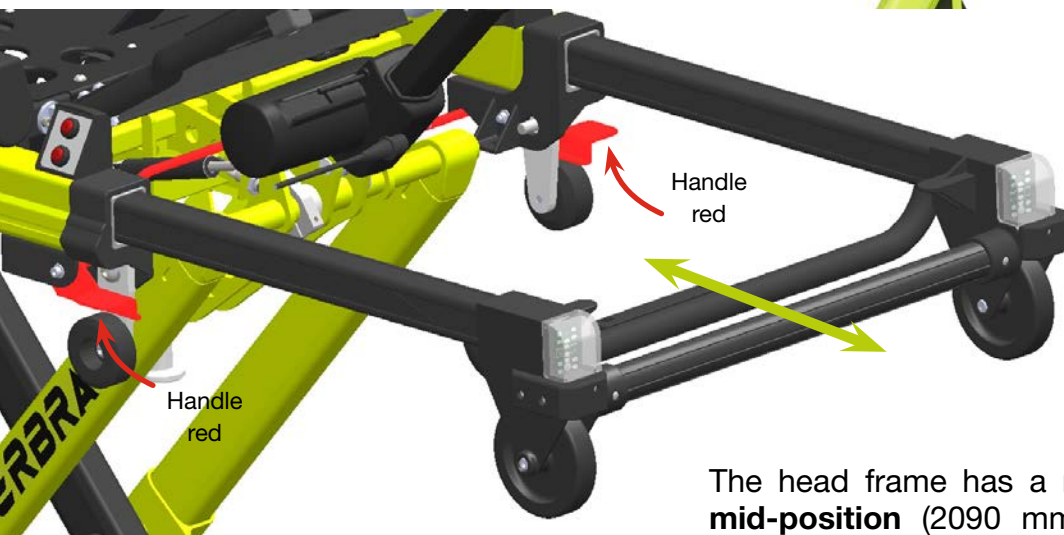

The head frame has a **mechanical end stop in mid-position** (2090 mm length), one in **folded position** (1723 mm) and one in **extended position**

(2210 mm). When the head frame range reaches each of these three positions, the red lever "clicks" back to its original position.

It is important that when the stretcher is positioned on the Superbravo rail, the position of the **front frame is intermediate**.. If in extended or folded position, damage to the stretcher and/or the operator could occur.

2.3.5. Adjustable leg

Button to adjust the inclination of the legs

By pressing this button and moving the leg rest manually, it is possible to adjust the positioning of the legs to the desired inclination. Once the inclination is correct and the button is released, the clamp is automatically locked in the required position.

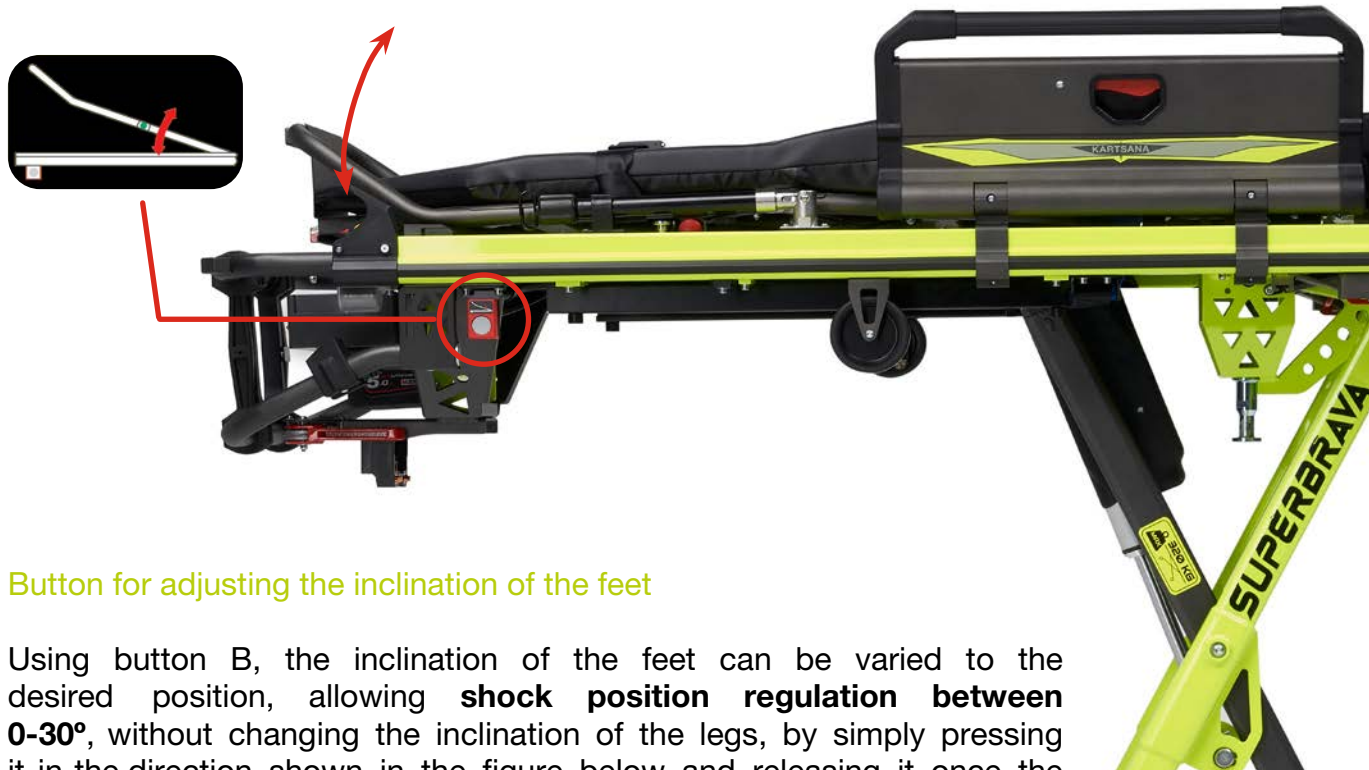

Button for adjusting the inclination of the feet

Using button B, the inclination of the feet can be varied to the desired position, allowing **shock position regulation between 0-30°**, without changing the inclination of the legs, by simply pressing it in the direction shown in the figure below and releasing it once the desired inclination has been achieved.



2.3.6. Safety railings

Safety rails can be adjusted from a fully horizontal position to a 90 degree position. The system allows the railing to be fixed in the 5 intermediate positions. The upward movement from the horizontal position to the 90°C position is done manually. Once the desired position has been reached, the position of the railing is automatically fixed.

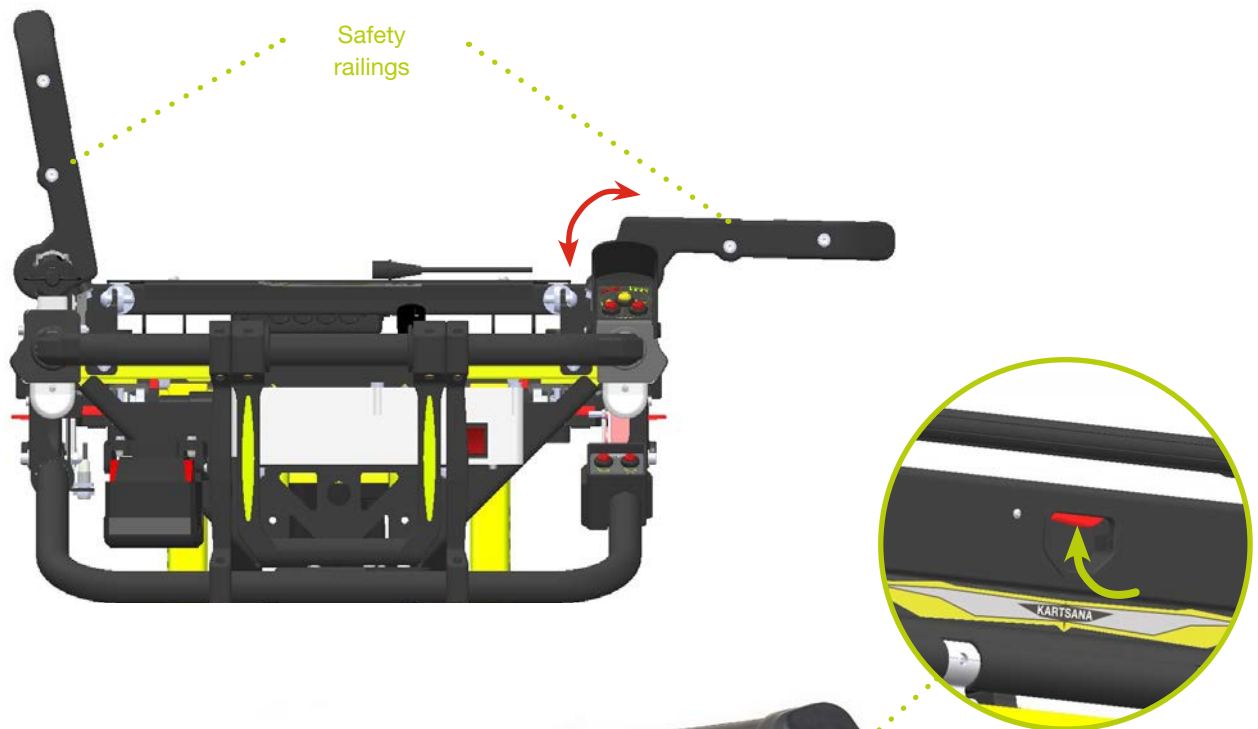

To unlock the system, the red handles must be pressed, releasing the system, and the handrails can be manually moved outwards from the stretcher.

2.3.7. Drip holder

The stretcher is equipped with two drip holders on both sides of the Superbrava lite (TG-2022) stretcher. Raise the drip profile to its upright position so that it can be fixed perpendicularly to the stretcher.

The length of the drip tube can be lengthened or shortened by unscrewing the fastenings of the telescopic rod. Lift the hook to the desired position and screw the fastener back in.

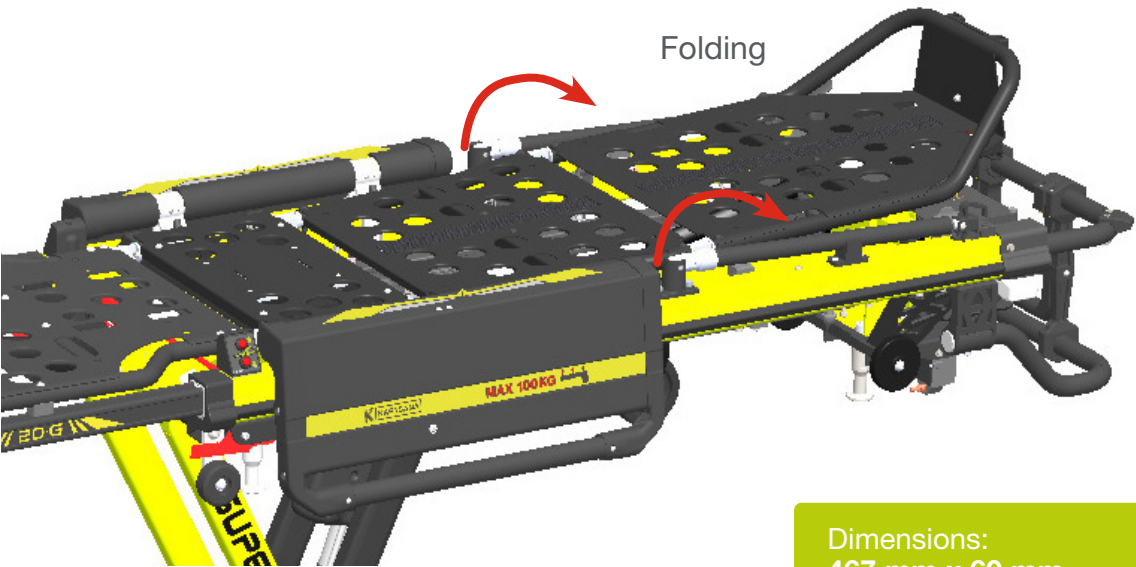

Dimensions:
467 mm x 60 mm
(extended is 390 mm longer)

Weight:
0.68 kg

Maximum permissible load: 6 Kg

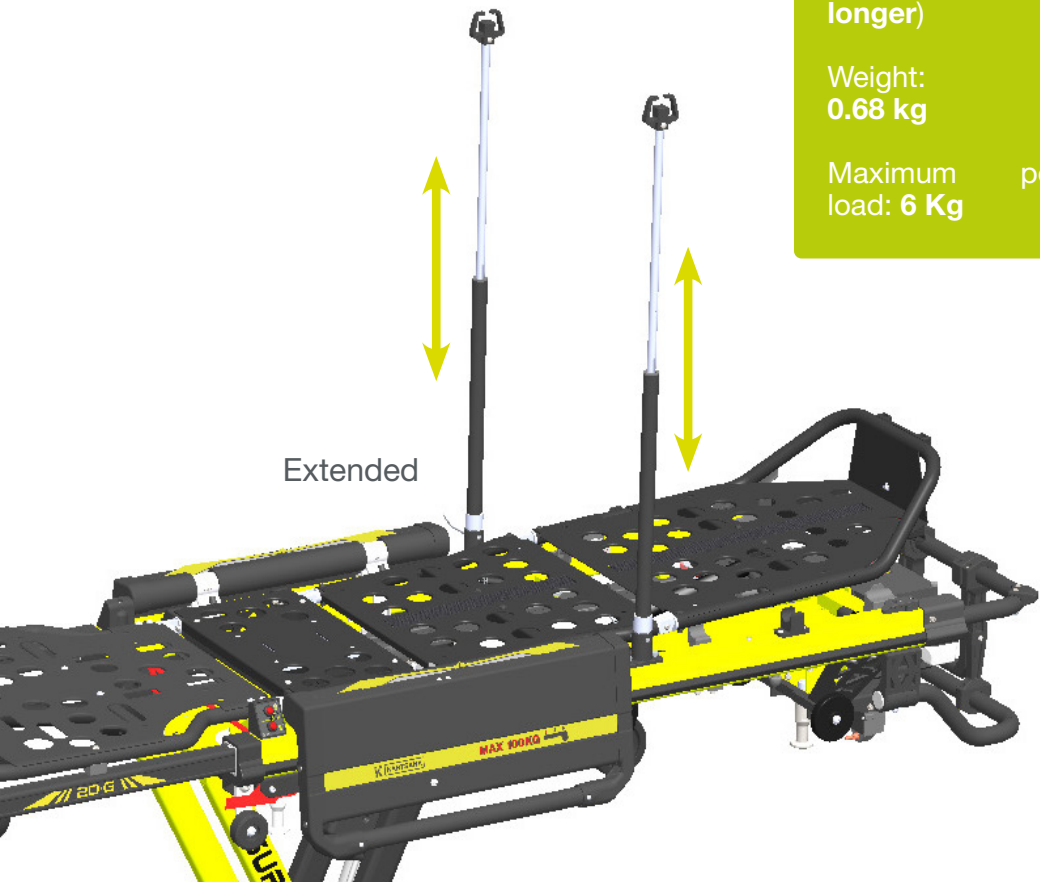

2.3.8. Safety belts



For -CR versions, use accessory C-119 (retractable belt).

Head belts:

The head belts are mounted crossed, always joining the upper and lower parts with the same colour.

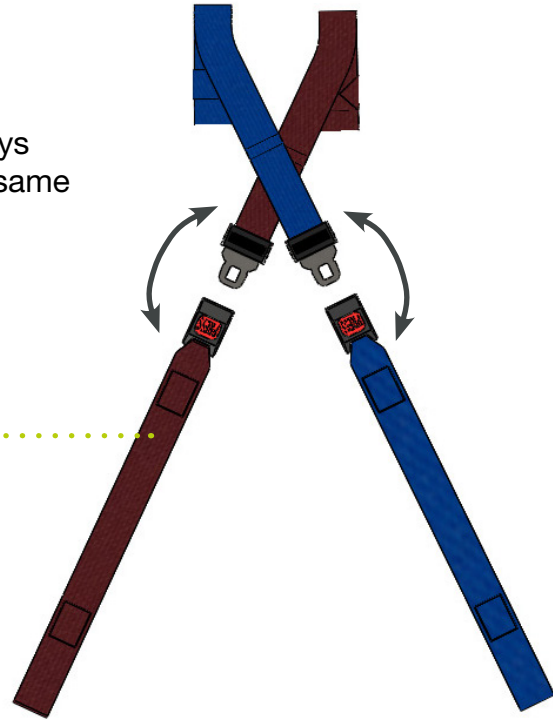

Lap and foot belts:

Place female buckle A and male buckle B in the position shown in the side figure and insert the latter into the groove of the former.

Once the assembly is secured, centre and tension the assembly by adjusting the tension of the belt using end C.

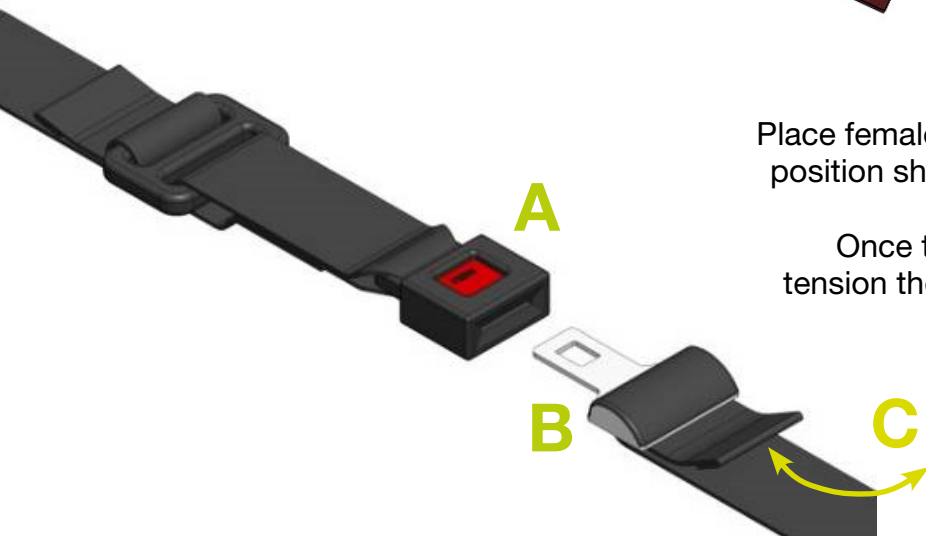

It is recommended that the patient is always secured with safety belts during the time he or she is on the stretcher.

Belt knot





2.3.9. Rear wheel brake lever

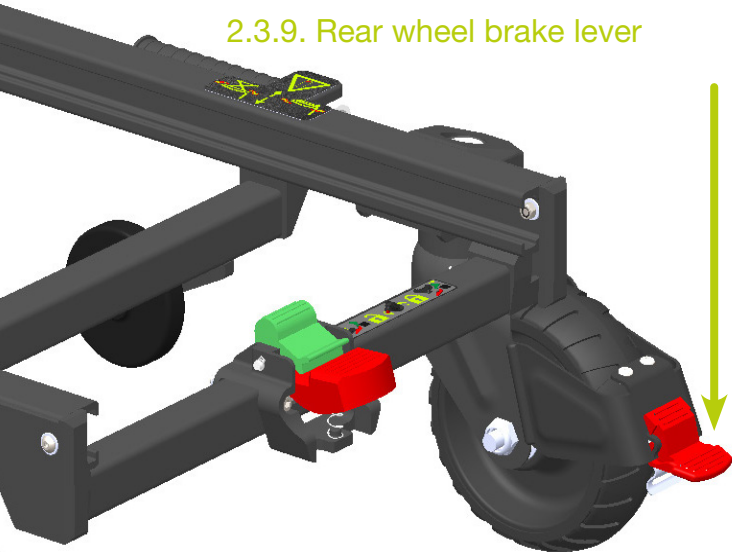

By pressing the lever indicated in the drawing with your foot, the rear wheels are locked by the brake. These assist in keeping the stretcher static, they should never be used as dynamic brakes.

2.3.10. Front wheel locking lever

Pressing the red central lever allows the wheels to turn freely.

Pressing the green rear lever blocks the free rotation of the wheels.

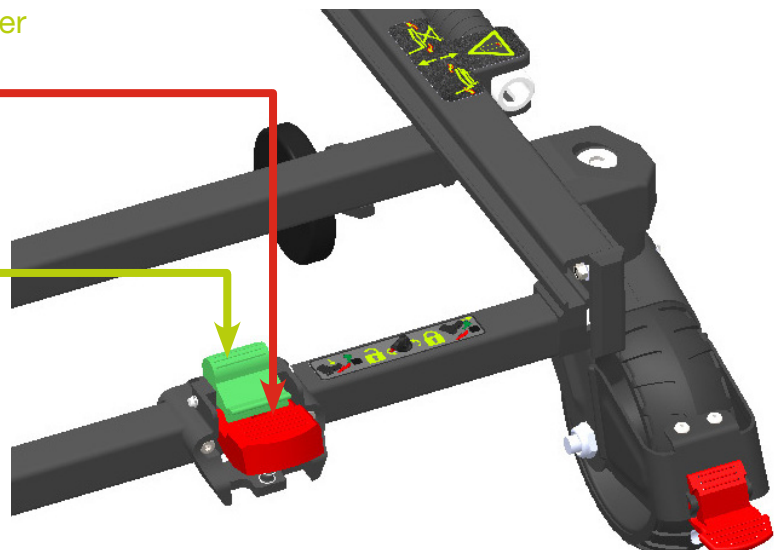

The front wheels must always be locked when loading the stretcher onto the rail. Failure to do so could damage important parts of the stretcher.



Do not operate the brake lever if there is a patient on the stretcher. The stretcher may tip over if moved with the brakes applied, with the risk of injury to the patient or operator, and damage to the stretcher.

Never leave a patient unattended on the stretcher, as this could result in injury; hold the stretcher securely when a patient is on it.

Do not install or use the stretcher brakes with excessively worn wheels. Installation or use of brakes on wheels with a diameter of less than 150 mm could result in malfunction and reduced braking power, with the risk of injury to the patient or operator and damage to the stretcher.



The wheel brakes are designed only to help limit the movement of the stretcher when it is not to be moved and to facilitate the transport of patients. The wheel brakes may not offer sufficient resistance on all surfaces or with weights of the wheels..

For a patient weighing more than 200 kg, it is recommended that a low position be used when transferring the patient, and the stretcher can be raised to the required position when the patient is transferred into the ambulance.

2.3.11. Assembly of the SUPERBRAVA LITE stretcher with SUPERBRAVO (R-2022) rail

The maximum range of the stretcher should only be adjusted **the first time** the stretcher is loaded onto the rail. If moving to another ambulance of a different height, **it will have to be readjusted**.

To set the maximum height of the stretcher's upward trajectory, the stretcher should be positioned in front of the deployed rail on the outside of the ambulance. Position the front wheels half a centimetre above the profile where the small load wheels slide. (see side picture).



- 1** The stretcher must be kept in this position when removed from the rail.
- 2** Then look for the adjustment cam on the top of the stretcher near the shock absorber attachment on the headrest.
- 3** Rotate the cam until the end-of-range light comes on.
- 4** Once in position, tighten the screw 8 Nm to fix the cam in its final position.

Thereafter, the stretcher **shall be raised** to the maximum level. Check the loading manoeuvre and readjust if necessary.

On uneven terrain or changes in gradient, the stretcher can be raised to its maximum range by pressing the right red and yellow button at the same time.

To load the stretcher onto the Superbravo rail, it must be in the outer position of the ambulance. Pull the red lever to release the block and remove it. Once outside, the stretcher is directed towards the ambulance's protruding profiles and the small wheels of the stretcher are aligned with the rail.

Loading the stretcher on the rail

1 With the rail removed, face the stretcher, centring the front wheels with the rail castings.



2 Push the stretcher as far as the front wheels will go.



The front wheels must **always be locked** when loading the stretcher onto the rail. Failure to do so could damage important parts of the stretcher.

3 Press the left button to raise the legs. Keep pressing it down until it no longer rises.



(*) If the operation is successful, the front axle should remain inside the hooks, and the LED for the stretcher folding on the frame will light up.

4 Operate the right rear red handle on the rail to unlock the mechanism and push the stretcher inwards until the end of the range is reached.



To ensure that the stretcher-rail assembly is securely attached, make sure that the release lever is in the horizontal position. The 3rd point being inside its housing.

If the stretcher receives power from the ambulance and the stretcher is in the correct position, battery charging starts. During the charging process, the battery LEDs will flash in a sweeping pattern, indicating that charging is in progress.

Once charging is complete, LED A turns on and the four red battery LEDs turn off.



Unloading of the stretcher when on the rail

To unload the stretcher, the procedure is as follows:

- 1 Lift the red central lever of the rail or press and hold the right front red button.

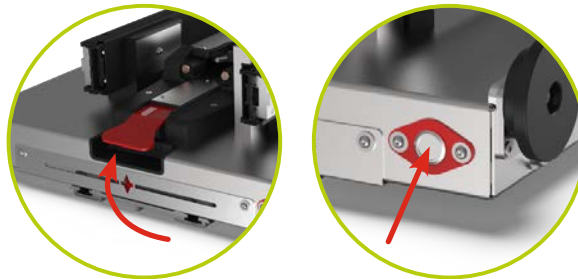

- 2 Slide the rail and stretcher until they stop.



- 3 Unfold the legs by pressing the right button on the control unit.





- 4** Pull the stretcher outwards and store the rail.

2.3.12. Transferring the patient to the stretcher

Transferring the patient to the stretcher

1. Move the stretcher towards the patient.
2. Place the stretcher next to the patient and raise or lower it to the patient's level.
3. Lower the side rails and open the restraining belts.
4. Transfer the patient to the stretcher using standard emergency medical services procedures.
5. Use all the restraining belts to secure the patient on the stretcher.
6. Adjust the backrest and footrest as required.

Moving the stretcher:

1. Ensure that all the restraining belts are secured above the patient.
2. There should be one operator at the lower end and one at the upper end of the stretcher at all times when moving the stretcher with a patient.
3. Approach door thresholds or other low barriers directly and lift the wheels over the obstacle separately, never all four at once.

Appropriate lifting techniques:

When lifting the stretcher and the patient, follow these five basic guidelines to help avoid injuries:

- ◇ Keep hands close to the body.
- ◇ Keep the back straight.
- ◇ Coordinate movements with your partner and lift with your legs.
- ◇ Avoid turning around.
- ◇ Always use the stretcher as described in this manual.

3. USE OF THE EMERGENCY LEVER



In the event of a hydraulic system failure, the stretcher can be operated manually. For the following procedure, **handling by two operators is necessary**. With the stretcher in the unfolded position, pull the red handle next to the battery at the rear of the stretcher. The stretcher will lower to the lower limit stop and remain in this position.

Emergency ascent
and descent

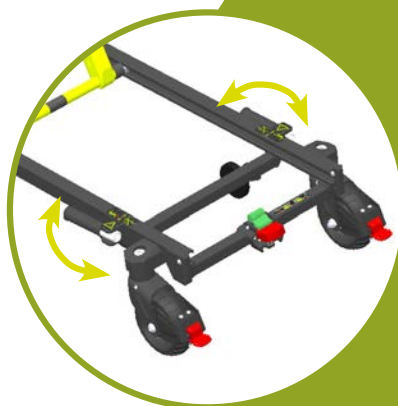

In the same way, by activating the handle and lifting the stretcher (always between two operators), the stretcher legs unfold until the handle is released, leaving them fixed in the adopted position.

If the stretcher is to be loaded onto the rail, it must be positioned on top of the block (as in the normal procedure) and the stretcher folded manually by pushing the handles on the underside of the chassis.

To insert the rail into the ambulance, the folded position of the stretcher must be held by hand until it is fixed in place.



4. CARE AND MAINTENANCE OF THE PRODUCT

4.1. Contact information

If you have any questions regarding the use, maintenance or installation of a KARTSANA product, please contact our Technical Service Area (SAT).

Telephone: +34 93 715 86 72
Email: sat@kartsana.com
Address: Narcís Monturiol, 34
08192 Sant Quirze del Vallès,
Barcelona (Spain)

4.2. Environmental conditions

Both for use and storage:

Recommended temperature: from -10°C to +60°C

Relative humidity: 5 – 95%

4.3. Cleaning

To clean the stretcher, use a cloth, rag or similar to wipe the surface to be cleaned with products that do not damage the surface of the materials. If the surface to be cleaned is already lubricated, re-grease it after cleaning has been completed.

Please use cleaning agents according to the manufacturer's instructions.



Do not wash the stretcher with pressurised water, take special care with electrical elements, housing, electronic board, keyboard, LEDs and motor.



Remove the batteries before washing and dry the terminal contacts afterwards.

The manufacturer shall not be liable for any damage or anomaly caused by a cleaning product that may damage the surface of the stretcher materials.

For reasons of hygiene and preservation of the product components, the manufacturer recommends cleaning after each use.

4.4. Maintenance

4.4.1 Precautionary maintenance

Correct and regular maintenance guarantees the durability of the product.

Creating a maintenance plan, including regular reviews and establishing a responsible person to carry them out, is recommended.

The person in charge must adhere to the following **requirements**:

- Possess technical knowledge related to the product and the maintenance procedures described in these instructions.
- To have the support of qualified, trained and knowledgeable staff who are familiar with the operation of the product.
- Use original or manufacturer-approved components, spare parts and accessories.
- In accordance with the instructions of the European Council Directive 93/42/EEC which establishes the obligation of the purchaser to provide on request the above mentioned after-sales care record for the purpose of product traceability, records of all product maintenance operations shall be kept.

Check for proper operation **before use**. Prior to service, the following should be checked:

- Functionality.
- Fastenings and hardware.
- Parts that move, such as wheels, belts and mattresses.
- Sensitivity of springs.
- Electrical functions: Full range of motion, lighting, etc.

If the device does not appear to be suitable for correct and safe use, **it should be taken out of service** until the device is repaired or restored to full working order.

Do not modify the structure of the device for any reason, as this may cause serious harm to patients and/or operators.

Lubrication intervals of moving parts:

- 1 – 30 services per month: every 3 months.
- 30 – 50 services per month: every 2 months.
- More than 150 services per month: every month.

All maintenance other than lubrication, tightening of nuts and bolts and ordinary cleaning must be carried out by KARTSANA or an authorised service centre.

4.4.2. Service maintenance

The person entrusted with the product review shall ensure the following basic requirements:

- ◇ Adequate knowledge of the product, its technical/constructional characteristics, control points and final tests, packaging, preservation and handling.
- ◇ Knowledge of all product functions and any possible risks, malfunctions or failures of the product.
- ◇ Possession of all necessary tools to carry out any technical service or minor repairs.
- ◇ Possession (or ability to procure) original manufacturer's or manufacturer's authorised spare parts.
- ◇ Use or support of specialised technical personnel trained by the manufacturer to service the product in question.
- ◇ Keeping a record of all maintenance operations carried out on the product, in accordance with the instructions of the European Council Directive 93/42/EEC which establishes the obligation of the purchaser to provide on request the above mentioned after-sales care record for the purpose of product traceability.

4.5. Transport and storage

Before transporting the device, ensure that it is properly packaged and secured to prevent damage during transportation.

Keep the original packaging for possible further transport. Any damage caused to the device during transport is not covered by the warranty.

Repairs and replacements of damaged parts are the responsibility of the customer. The device should be stored in a dry place.

When storing, do not place any heavy objects on top of the product. It must not be used as a support for any kind of object.

4.6. Disposal

When the product is no longer in a usable condition, do not throw it away but develop a take-back strategy for recycling by an authorised dealer. The packaging shall be managed as reusable waste. Metals are fully recyclable. Plastic products should be treated as recycling material. Waste management should be as established in each country. If you have any questions, please ask your municipal administration.

5. SPARE PARTS

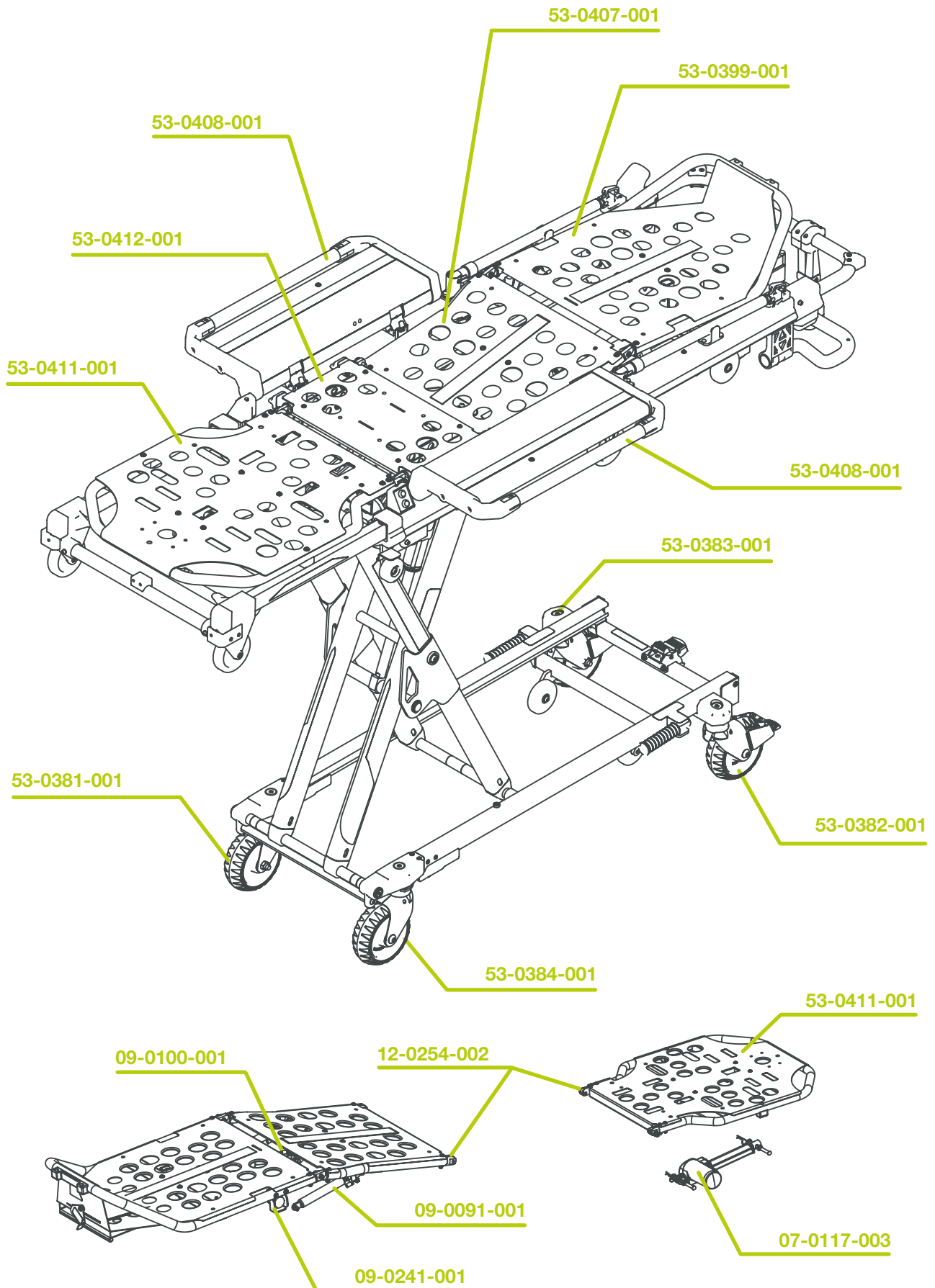

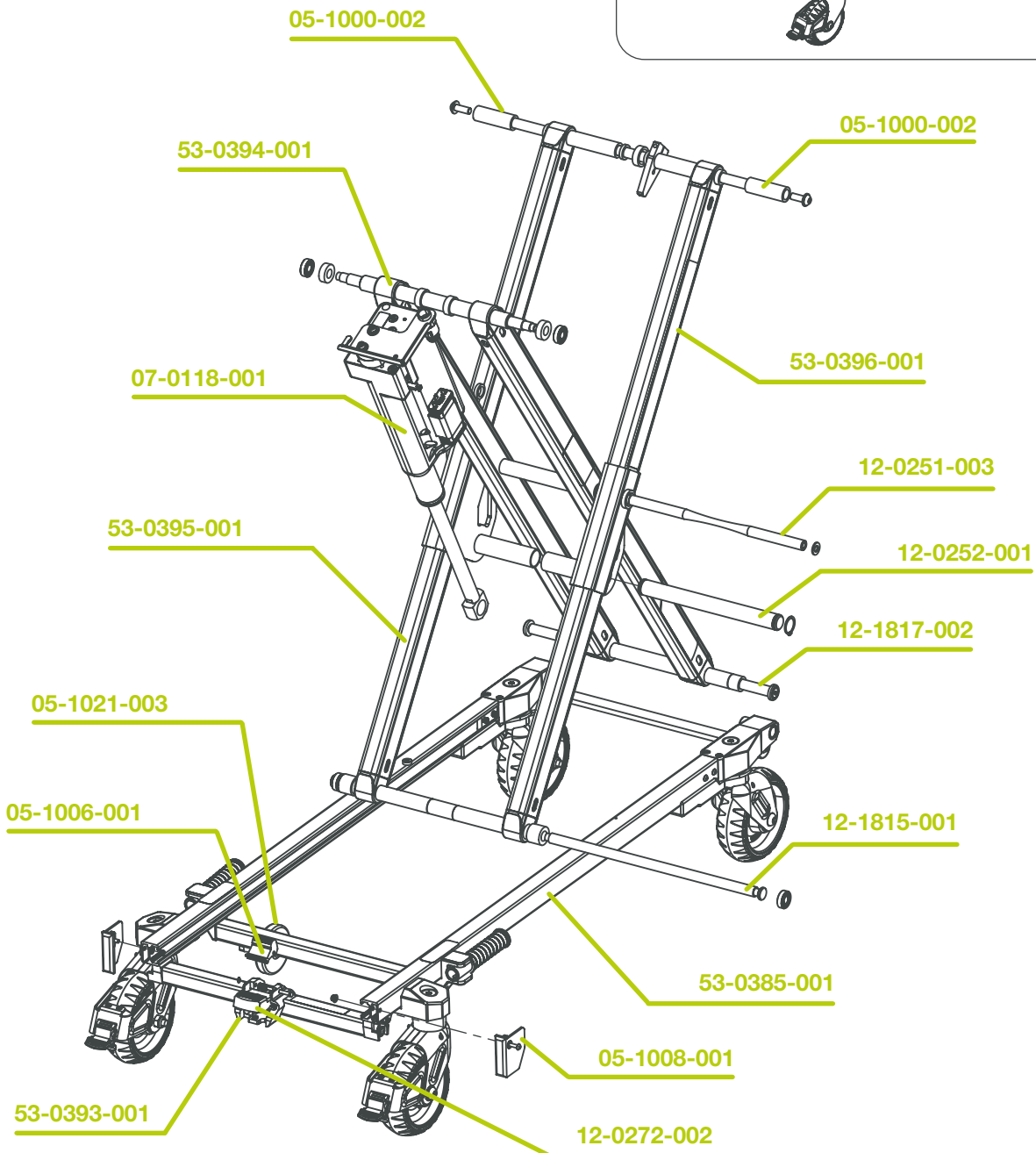
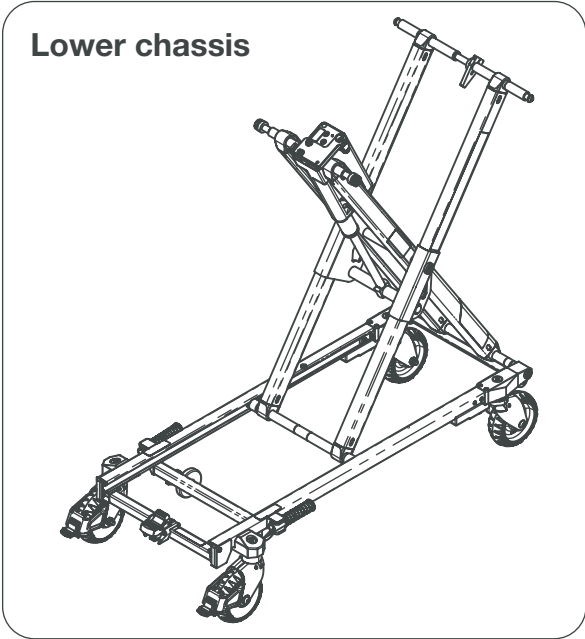

Patient area

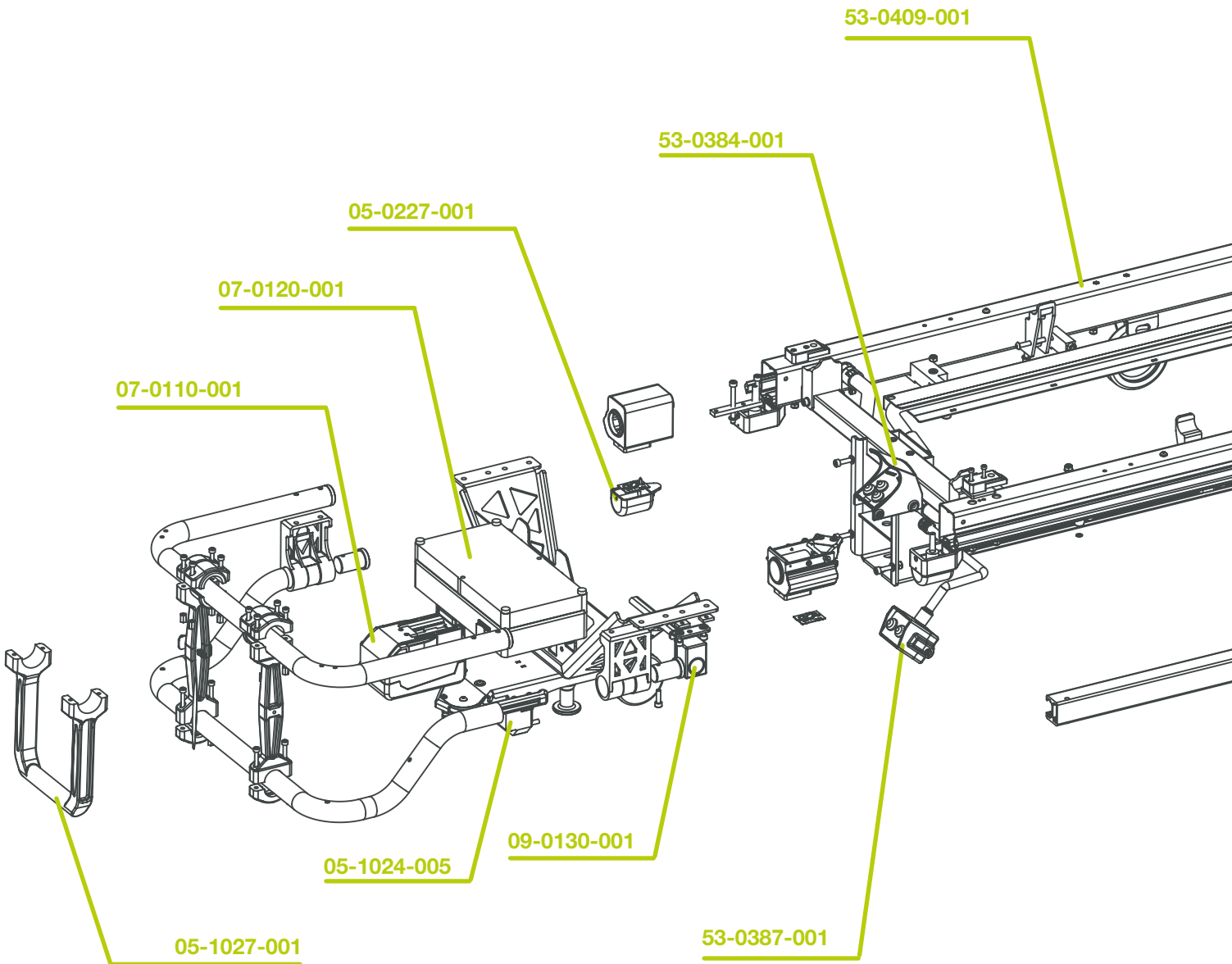
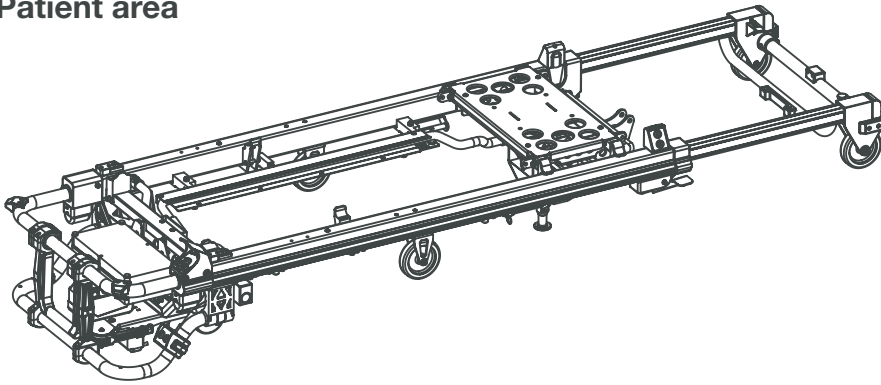

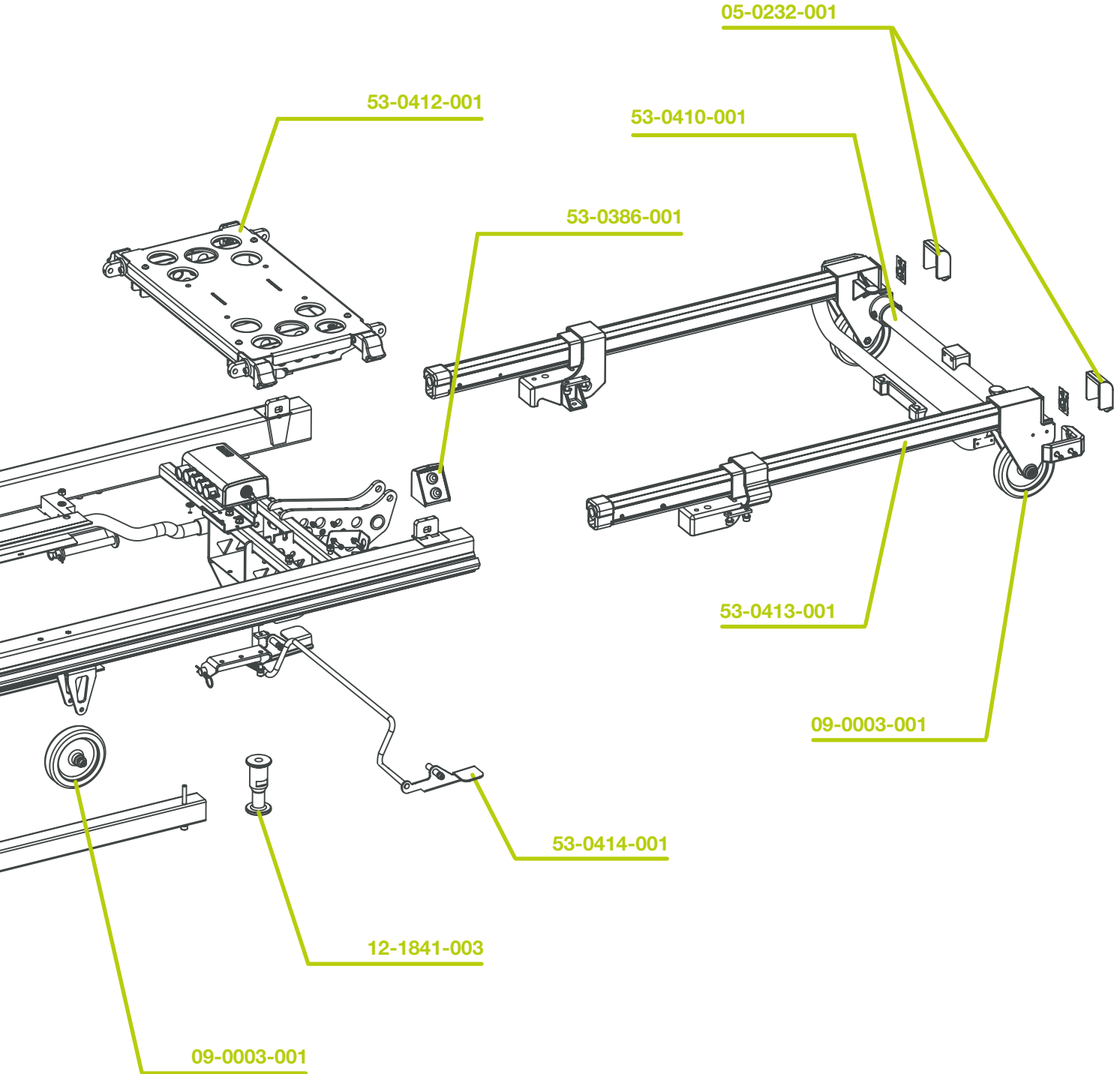

6. STRETCHER ACCESSORIES

C-094 Superbrava Bariatric Kit



C-098 Extendable head



C-095 Oxygen bottle holder



C-040 Corpuls support



C-097 Instrument table



C-092 Extendable handles



C-091 Accessories bag



P-105 Paediatric mattress



07-0110 Battery



07-0112 Battery charger



C-090 Drip tube



P-107 Heated mattress



C-093 Utensil table



7. SYSTEM ERRORS

When an error occurs, the **stretcher becomes inactive** with:

- Folded stretcher indicator flashing.
- Stretcher lights flashing.
- The marking of the error code by a combination of the four yellow error LEDs.



To exit the **Error status**:
Press the red UP button + the red DOWN button + the yellow LIGHT button
at the same time for 2 sec.

If you wish to switch off the LED lights during an error, you must press the yellow LIGHT button.

7.1. Error codes

ERROR NAME	CODE	LEDs			
		A	B	C	D
Battery Charging Error due to NOT exceeding minimum voltage	1			●	
Charge Intensity Error VERY HIGH Batteries	2			●	●
Battery Charging Error due to lack of Ambulance Voltage	3		●		
DISCHARGED or VERY LOW Batteries	4		●		●
Ambulance Switch Error	5		●	●	
Charger Error due to lack of battery, or stretcher disconnected	6		●	●	●
Load Error due to exceeding Duty max in PWM	7	●			
Error in Upward Movement due to excessive time	8	●			●
Error in Downward Movement due to excessive time	9	●		●	
Error in Motor due to exceeding maximum current	10	●		●	●
Error in Motor due to low voltage	11	●	●		

7.2. Troubleshooting

The following table summarises the possible errors and their respective solutions.

In addition, it is advisable **to remove the battery if the stretcher is not going to be used** for long periods of time.

TROUBLESHOOTING			
CODE	DESCRIPTION OF THE ERROR	POSSIBLE CAUSE OF THE ERROR	ERROR SOLUTION
1	The battery voltage is less than 3V. The battery is disconnected or damaged.	Battery disconnected	Connect the batteries to the battery connector correctly.
			Check that the battery cables are properly connected to the electronics board.
		Damaged battery	Replace with a new battery.
2	The battery voltage is higher than 34V.	An overload has occurred in the battery recharging process. (Use only the charger supplied by KARTSANA or the stretcher for battery recharging).	Leave the battery idle, preferably in a cool place, for 3 to 4 hours (or until it does not show error 2 when connected to the stretcher) to allow it to self-discharge. Check that the batteries have not been damaged internally by discharging them by moving the stretcher up and down. It should provide at least 15 cycles before discharging.
		Damaged battery	Replace with a new battery.
3	The stretcher does not receive voltage from the ambulance.	The stretcher-rail plug is not connecting correctly	Check that the two contacts of the stretcher plug and the rail are touching each other and that there is no foreign body between them.
		Ambulance battery is discharged or damaged.	Charge the battery or replace it with a new one, respectively.
		Power cables incorrectly connected either on the ambulance, rail or stretcher.	Check connection of the cables. Recommended order of testing: ambulance, rail and stretcher.
		One of the copper contacts of the stretcher plug has not come out of its housing completely in the plastic part.	Check that the plug contacts move smoothly in and out of the socket.
4	The battery voltage is less than 18V.	Discharged battery	Charge the battery in the charger and not in the vehicle.
5	The stretcher is receiving power from the socket, but the position sensor has not been activated.	The stretcher has not fully entered the rail.	Position it correctly inside the rail.
			Adjust the position sensor.
6	Battery is not detected.	Disconnected batteries	Push them fully into the clamping plate until you hear a clicking sound.
		Damaged battery	Replace with a new battery.
		Very low battery	Charge with external charger.
7	Failure in charging process.	Contact technical support	Contact technical support.

8	More than 9 seconds have passed in an upward motion.	Discharged battery	Charge the battery
		Hydraulic system failure.	Contact technical support.
		The mechanism does not move freely.	Check for excessive friction or interference between the mechanical parts.
9	More than 9 seconds have elapsed in downward motion.	Discharged battery	Charge the battery
		Hydraulic system failure	Check for possible oil leaks. Contact technical support.
		The mechanism does not move freely	Check for excessive friction or interference between the mechanical parts.
10	Current greater than 48A.	Overloaded stretcher	Do not load the stretcher with loads of more than 320 Kg.
		Discharged battery	Charge the battery
		The mechanism does not move freely.	Check for excessive friction, blockage or interference between the mechanical parts.
11	Lower voltage of 15V.	Overloaded stretcher	Do not load the stretcher with loads of more than 320 Kg.
		Discharged battery	Charge the battery
		The mechanism does not move freely.	Check for excessive friction, blockage or interference between the mechanical parts.

7.3. Motor protection

The system switches off in the following situations:

- By Time-out of 9 sec (*error 8 and 9*)
- For Intensity greater than 60A for more than 0.5 sec (*error 10*)
- For Motor Battery Voltage less than 18 Volt (*error 4*)

7.4. Ambulance entry

If there is ambulance entry, 4 different cases can occur:

- 1) Stretcher on without ambulance voltage:** the LEDs will be off waiting for vehicle voltage. After 10 seconds the LEDs on the stretcher flash (*error 3*). They will stop flashing once the stretcher receives ambulance voltage.
- 2) Stretcher off with ambulance voltage:** LEDs off waiting for ambulance voltage. Accordingly, before bringing the stretcher into the ambulance, check that the battery button is pressed.
- 3) Stretcher off in ambulance:** LEDs off waiting for battery detection. After 3 seconds the LEDs on the stretcher flash (*error 6*). They will stop flashing when the stretcher is turned on.
- 4) Stretcher switched on in ambulance:** if it receives ambulance voltage and sensor position OK, battery charging starts. Once the charging process is completed, the upper error LED and the 4 red LEDs light up simultaneously.

7.5. Battery charging

When entering the ambulance, the battery is tested for 10 seconds to check that its voltage is between 3 and 34 Volts. Furthermore, 100 mA current is applied to check that the battery is connected. The battery charging process consists of 2 phases.

For the first phase, one of the following conditions must be met:

- The previous upload was incomplete
- The battery is discharged
- The battery has a voltage of less than 25.6 Volts.

PHASE 1

It consists of 3 consecutive steps (must be completed to determine that the battery is charged):

1) Start of charging:

Charge with a steady current of 750mA until one of the following conditions is met:

Voltage greater than 24 Volts
Maximum time 20 minutes
Ambulance departure
Error by:

Duty Max
Voltage greater than 30.4 Volts
Current greater than 6.0A
Does not exceed the minimum voltage of 17.6 V within 30 minutes

2) Fast charging:

Charging at a constant current of 1.8A until one of the following conditions is met:

The voltage of 28.8 Volts is reached
Maximum time 120 min
Ambulance departure
Error by:

Duty Max
Voltage greater than 30.4 Volts

3) Full charge:

Charge at a constant voltage of 28.8 volts until one of the following conditions is met:

Maximum time 60 minutes
Ambulance departure
Error by:

Duty Max
Voltage greater than 30.4 Volts
Current greater than 6.0A

For the second phase, it is only required **that no errors have occurred**.

PHASE 2.

Consists of 1 step, in this case, the maintenance charge does not need to be completed:

1) Maintenance charge:

Charge with a constant current of 80mA until one of the following conditions is met:

Maximum time 10 minutes
The saturation voltage of 29.04 Volts is reached.
Ambulance departure
Error by:

Duty Max
Voltage greater than 30.4 Volts



If the battery falls below 20 Volts, the battery must be charged by the battery charger and not by ambulance (*error 4*)

8. INCUBATOR VERSION

8.1 Product description

The **SUPERBRAVA INCUBATOR (TG-2022 IN)** stretcher has been specifically designed for the transport of incubators. The product complies with the MDR (EU) Directive 2017/745. It is an electro-hydraulic model that enables the adjustment of the working height according to individual need, with just two push buttons.

This product has the same measurements and functionalities as the SUPERBRAVA LITE stretcher, except for the upper part, which does not have a head and leg rest, but consists of a metal plate where the incubator is fixed. The main characteristics of the stretcher can be found below.

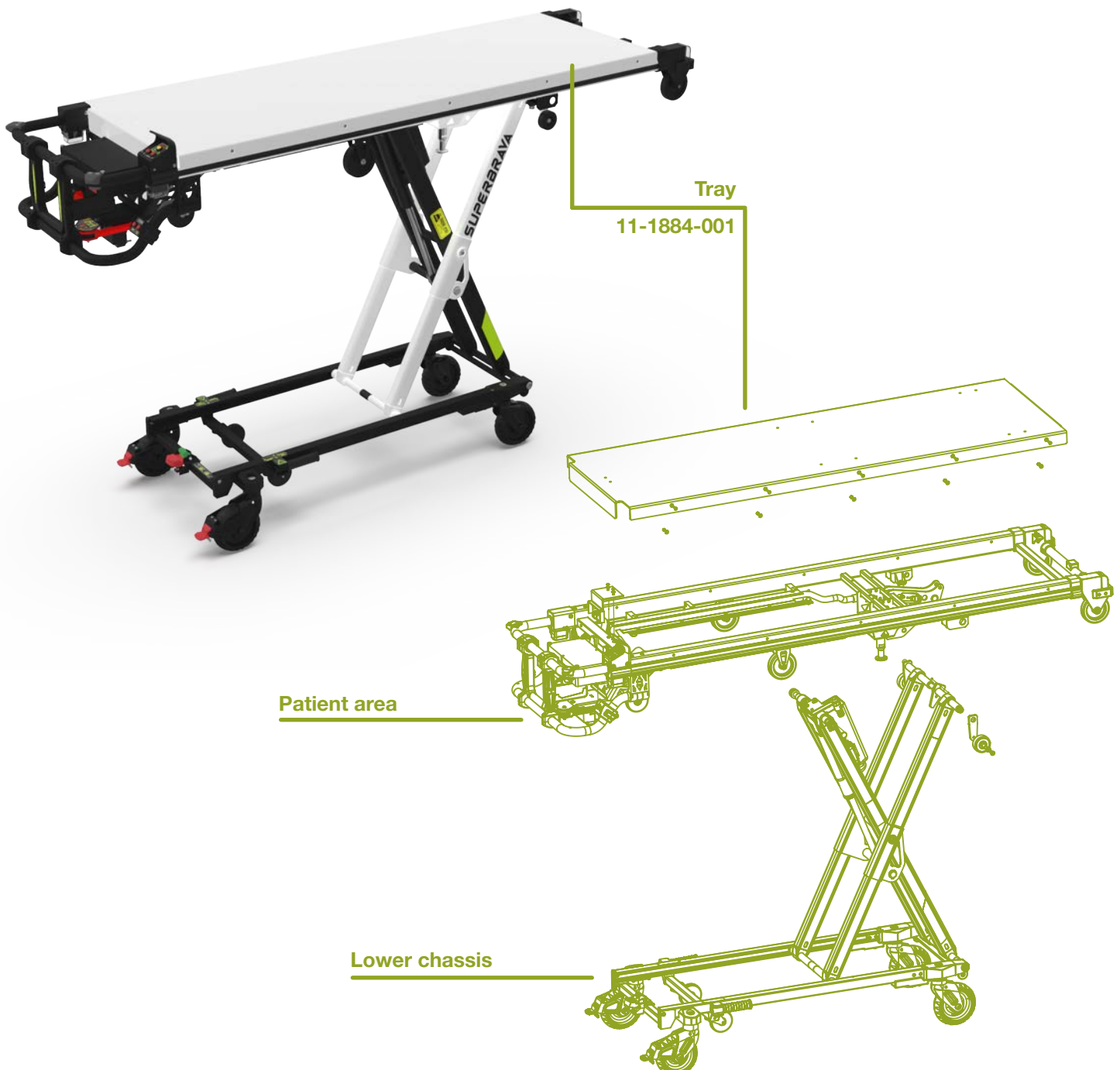



8.2 Measures

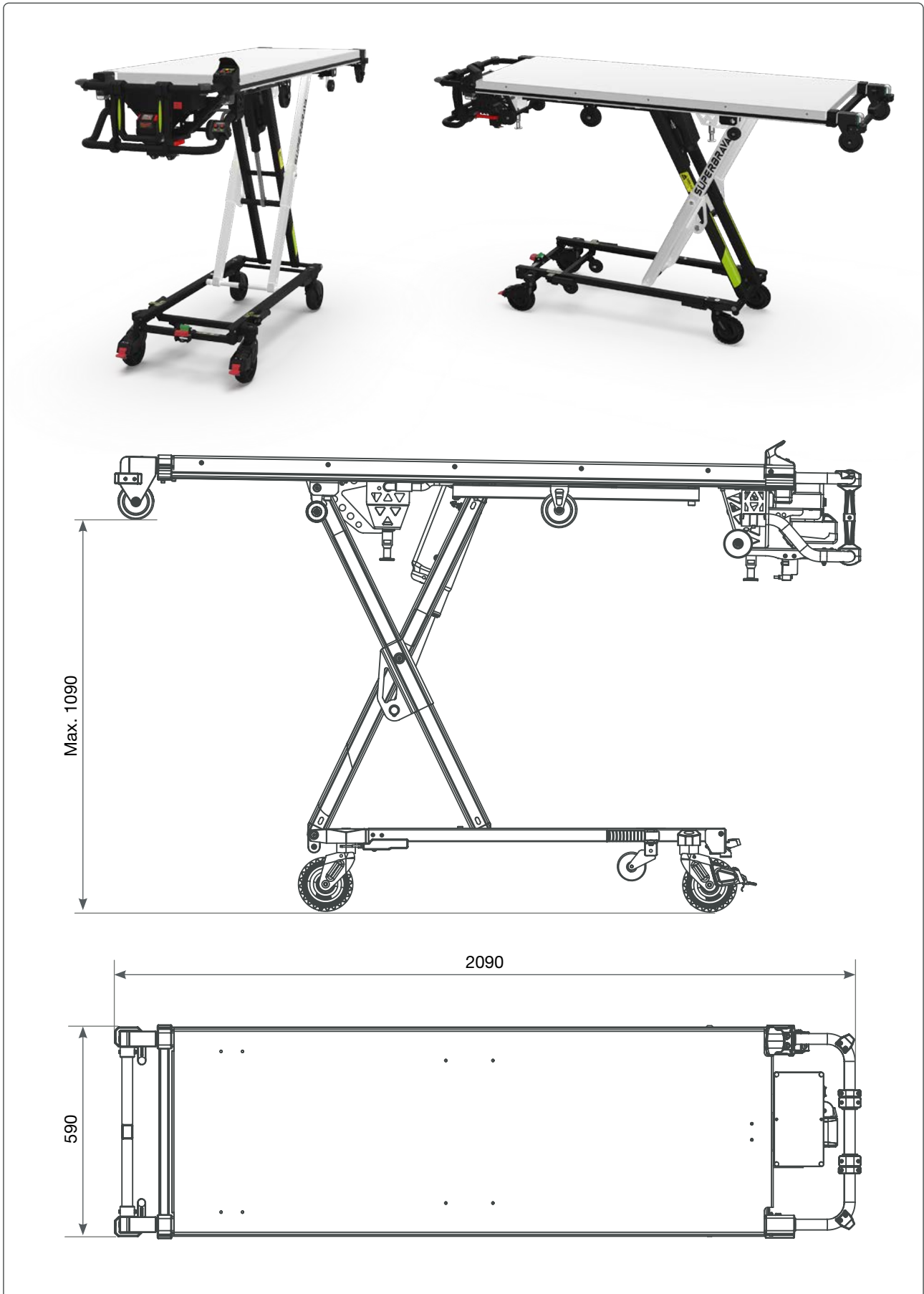



KARTSANA

Life-moving innovation

Headquarters

C/ Narcís Monturiol, 34
08192 - Sant Quirze del Vallès
Barcelona (España)
(+34) 93 715 86 72
info@kartsana.com
www.kartsana.com



Technical Service

sat@kartsana.com

Contacte con nuestro servicio técnico
para cualquier duda o consulta.

*Contact our technical service for any
question or doubt.*

Veuillez contacter notre service
technique pour toute question ou
demande de renseignements.